

## Finish 370

## Finish 250

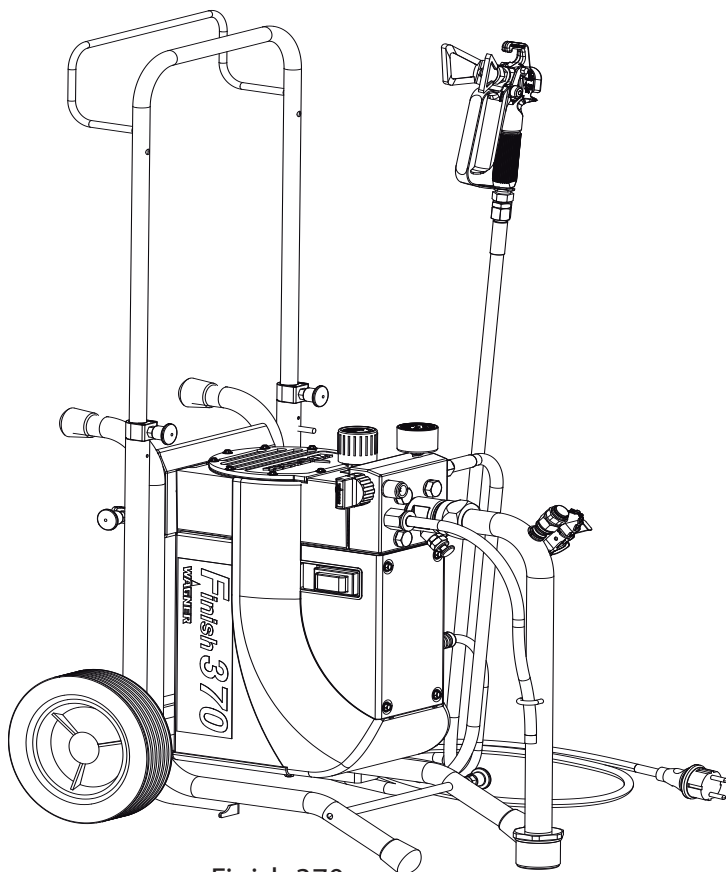

Finish 370

0252 882

11 / 2007

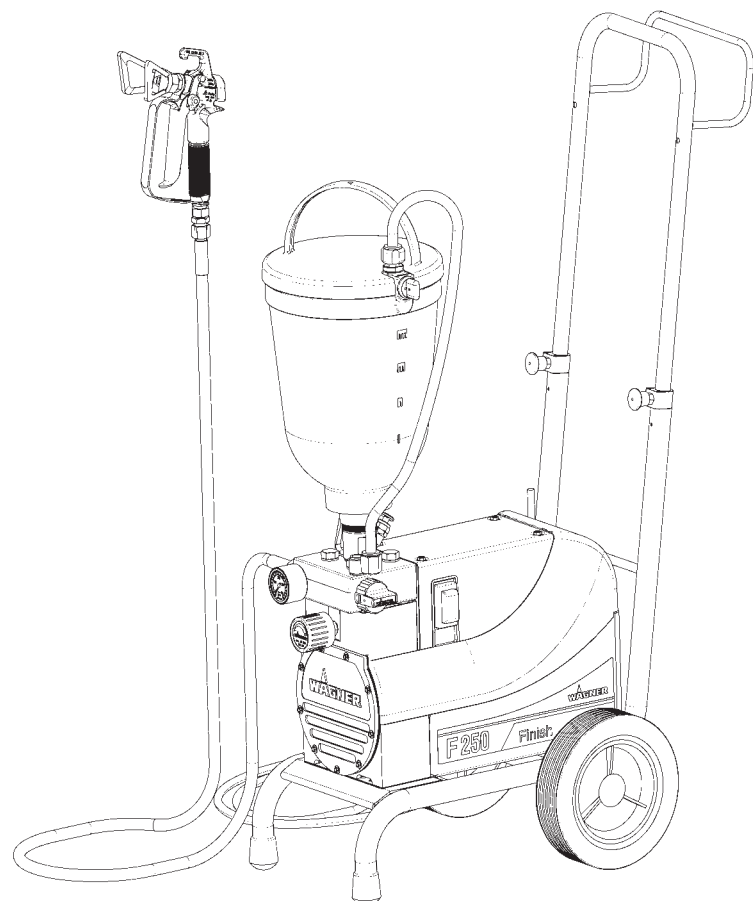

Finish 250

# WARNING!

**Attention, danger of injury by injection!**

**Airless units develop extremely high spray pressures.**

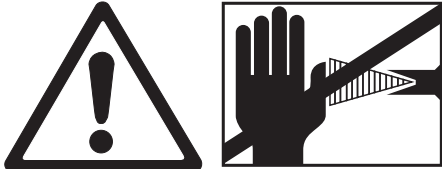
	 <p><b>Danger</b></p>
<p>①</p>	<p>Never bring fingers, hands or other body parts into contact with the spray jet! Never point the spray gun at yourself, other persons or animals. Never use the spray gun without spray jet safety guard.</p> <p>Do not treat a spray injury as a harmless cut. In case of injury to the skin by coating material or solvents, consult a doctor for quick and correct treatment. Inform the doctor about the coating material or solvent used.</p>
<p>②</p>	<p><b>The following points are to be observed in accordance with the operating manual before every start-up:</b></p> <ol style="list-style-type: none"><li>1. Faulty units may not be used.</li><li>2. Secure a Wagner spray gun with the securing lever at the trigger guard.</li><li>3. Ensure earthing.</li><li>4. Check the permissible operating pressure of the high-pressure hose and spray gun.</li><li>5. Check all the connecting parts for leaks.</li></ol>
<p>③</p>	<p><b>Instructions for regular cleaning and maintenance of the unit are to be observed strictly.</b></p> <p><b>Observe the following rules before any work on the unit and at every working break:</b></p> <ol style="list-style-type: none"><li>1. Relieve the pressure from the spray gun and high-pressure hose.</li><li>2. Secure a Wagner spray gun with the securing lever at the trigger guard</li><li>3. Switch the unit off.</li></ol>

## Ensure safety!

## Contents

<b>1</b>	<b>SAFETY REGULATIONS FOR AIRLESS SPRAYING</b>	<b>4</b>	4.6	Ventilate unit (hydraulic system) if the sound of inlet valve is not audible	11
1.1	Flash point	4	4.7	Taking the unit into operation with coating material	11
1.2	Explosion protection	4	<b>5</b>	<b>SPRAYING TECHNOLOGY</b>	<b>12</b>
1.3	Danger of explosion and fire from sources of ignition during spraying work	4	<b>6</b>	<b>HANDLING THE HIGH-PRESSURE HOSE</b>	<b>12</b>
1.4	Danger of injury from the spray jet	4	6.1	High-pressure hose	12
1.5	Secure spray gun against unintended operation	4	<b>7</b>	<b>INTERRUPTION OF WORK</b>	<b>12</b>
1.6	Recoil of spray gun	4	<b>8</b>	<b>CLEANING THE UNIT</b>	<b>13</b>
1.7	Breathing equipment as protection against solvent vapors	4	8.1	Cleaning the unit from the outside	14
1.8	Prevention of occupational illnesses	5	8.2	Suction filter	14
1.9	Max. operating pressure	5	8.3	High-pressure filter	14
1.10	High-pressure hose (safety instructions)	5	8.4	Cleaning the Airless spray gun	15
1.11	Electrostatic charging (formation of sparks or flames)	5	<b>9</b>	<b>SERVICING</b>	<b>15</b>
1.12	Use of units on building sites and workshops	5	9.1	General servicing	15
1.13	Ventilation when spraying in rooms	5	9.2	High-pressure hose	15
1.14	Suction installations	5	<b>10</b>	<b>REPAIRS AT THE UNIT</b>	<b>16</b>
1.15	Earthing of the object	5	10.1	Inlet valve Pusher	16
1.16	Cleaning the unit with solvents	5	10.2	Inlet valve	16
1.17	Cleaning the unit	5	10.3	Outlet valve	16
1.18	Work or repairs at the electrical equipment	5	10.4	Pressure control valve	17
1.19	Work at electrical components	5	10.5	Relief valve	17
1.20	Setup on an uneven surface	6	10.6	Replacing the diaphragm	17
<b>2</b>	<b>GENERAL VIEW OF APPLICATION</b>	<b>6</b>	10.7	Replacing the power cable	18
2.1	Application	6	10.8	Typical wear parts	18
2.2	Coating material	6	10.9	Connection diagram	19
2.2.1	Coating materials with sharp-edged additional materials	6	10.10	Remedy in case of faults	20
2.2.2	Filtering	6	<b>11</b>	<b>SPARE PARTS AND ACCESSORIES</b>	<b>21</b>
<b>3.</b>	<b>DESCRIPTION OF UNIT</b>	<b>7</b>	11.1	Finish 370 / 250 accessories	21
3.1	Airless process	7	11.2	Spare parts list Pump head	22
3.2	Functioning of the unit	7	11.3	Spare parts list Pump-Aggregate	23
3.3	Explanatory diagram	8	11.4	Spare parts list high-pressure filter	25
3.4	Transportation	8	11.5	Spare parts List Trolley	25
3.5	Trolley backfitting (only Finish 370)	8	11.6	Spare parts list suction system (rigid)	26
3.6	Technical data Finish 250	9	11.7	Spare parts list hopper 5l	27
3.7	Technical data Finish 370	9	11.8	Spare parts list hopper with TopClean	27
<b>4</b>	<b>STARTUP</b>	<b>10</b>	CE-declaration	28	
4.1	Unit with suction system	10	Service network	29	
4.2	unit with upper hopper (5 litres)	10	Testing of the unit	30	
4.3	high pressure hose and spray gun	10	Important information on product liability	30	
4.4	Connection to the mains network	10	Guarantee declaration	30	
4.5	Cleaning preserving agent when starting-up of operation initially	11			

## 1 SAFETY REGULATIONS FOR AIRLESS SPRAYING

The safety-specific requirements for Airless spraying are specified in:

- The European Standard „Spray equipment for coating materials – safety regulations „ (EN 1953: 1998).
- The regulations of the German employer’s liability insurance association („Berufsgenossenschaft“) „Using liquid jets“ (BGV D15) and „Processing coating materials „ (BGV D25).
- Guidelines for construction and implementation requirements for liquid jets (spraying units) of the German industrial employer’s liability insurance association (ZH1/406).

The following safety regulations are to be observed in order to ensure safe handling of the Airless high-pressure spraying unit.

### 1.1 FLASH POINT

 <b>Danger</b>	<p>Only spray coating materials with a flash point of 21 °C or higher.</p> <p>The flash point is the lowest temperature at which vapors develop from the coating material. These vapors are sufficient to form an inflammable mixture over the air above the coating material.</p>
---	--



### 1.2 EXPLOSION PROTECTION

 <b>Danger</b>	<p>Do not use the unit in work places which are covered by the explosion protection regulations.</p> <p>The unit is not designed to be explosion protected.</p>
---	---

### 1.3 DANGER OF EXPLOSION AND FIRE FROM SOURCES OF IGNITION DURING SPRAYING WORK

 <b>Danger</b>	<p>There must be no sources of ignition such as, for example, open fires, lit cigarettes, cigars or tobacco pipes, sparks, glowing wires, hot surfaces, etc. in the vicinity.</p>
---	---

### 1.4 DANGER OF INJURY FROM THE SPRAY JET

 <b>Danger</b>	<p>Attention, danger of injury by injection! Never point the spray gun at yourself, other persons or animals.</p> <p>Never use the spray gun without spray jet safety guard.</p> <p>The spray jet must not come into contact with any part of the body.</p> <p>In working with Airless spray guns, the high spray pressures arising can cause very dangerous injuries. If contact is made with the spray jet, coating material can be injected into the skin. Do not treat a spray injury as a harmless cut. In case of injury to the skin by coating material or solvents, consult a doctor for quick and correct treatment. Inform the doctor about the coating material or solvent used.</p>
	

### 1.5 SECURE SPRAY GUN AGAINST UNINTENDED OPERATION

Always secure the spray gun when mounting or dismounting the tip and in case of interruption to work.

### 1.6 RECOIL OF SPRAY GUN

 <b>Danger</b>	<p>When using a high operating pressure, pulling the trigger guard can effect a recoil force up to 15 N.</p> <p>If you are not prepared for this, your hand can be thrust backwards or your balance lost. This can lead to injury.</p>
--	--

### 1.7 BREATHING EQUIPMENT AS PROTECTION AGAINST SOLVENT VAPORS

Wear breathing equipment during spraying work.

A breathing mask is to be made available to the user (regulations of the German employer’s liability insurance association („Berufsgenossenschaft“) „Rules for the use of breathing masks“ (BGR 190), „Using liquid jets“ (BGV D15) and „Processing coating materials „ (BGV D25).

## 1.8 PREVENTION OF OCCUPATIONAL ILLNESSES

Protective clothing, gloves and possibly skin protection cream are necessary for the protection of the skin.

Observe the regulations of the manufacturer concerning coating materials, solvents and cleaning agents in preparation, processing and cleaning units.

## 1.9 MAX. OPERATING PRESSURE

The permissible operating pressure for the spray gun, spray gun accessories, unit accessories and high-pressure hose must not fall short of the maximum operating pressure of 25 MPa (250 bar or 3625 psi).

## 1.10 HIGH-PRESSURE HOSE (SAFETY INSTRUCTIONS)

An electrostatic charging of spray guns and the high-pressure hose is discharged through the high-pressure hose. For this reason the electric resistance between the connections of the high-pressure hose must be equal to or lower than 1 MΩ.

	Only use WAGNER original-high-pressure hoses in order to ensure functionality, safety and durability.
---	---

## 1.11 ELECTROSTATIC CHARGING (FORMATION OF SPARKS OR FLAMES)

 Danger	Electrostatic charging of the unit may occur during spraying due to the flow speed of the coating material. These can cause sparks and flames upon discharge. The unit must therefore always be earthed via the electrical system. The unit must be connected to an appropriately-grounded safety outlet.
---	---

## 1.12 USE OF UNITS ON BUILDING SITES AND WORKSHOPS

The unit may only be connected to the mains network via a special feeding point with a residual-current device with INF ≤ 30 mA.

## 1.13 VENTILATION WHEN SPRAYING IN ROOMS

Adequate ventilation to ensure removal of the solvent vapors has to be ensured.

## 1.14 SUCTION INSTALLATIONS

The are to be provided by the unit user in accordance with the corresponding local regulations.

## 1.15 EARTHING OF THE OBJECT

The object to be coated must be earthed. (Building walls are usually earthed naturally)

## 1.16 CLEANING THE UNIT WITH SOLVENTS

 Danger	When cleaning the unit with solvents, the solvent should never be sprayed or pumped back into a container with a small opening (bunghole). An explosive gas/air mixture can arise. The container must be earthed.
---	---

## 1.17 CLEANING THE UNIT

 Danger	Danger of short-circuits caused by water ingress! Never spray down the unit with high-pressure or high-pressure steam cleaners.
---	--

## 1.18 WORK OR REPAIRS AT THE ELECTRICAL EQUIPMENT

These may only be carried out by a skilled electrician. No liability is assumed for incorrect installation.

## 1.19 WORK AT ELECTRICAL COMPONENTS

Unplug the power plug from the outlet before carrying out any repair work.

## 1.20 SETUP ON AN UNEVEN SURFACE

The front end must always point downwards in order to avoid sliding away.

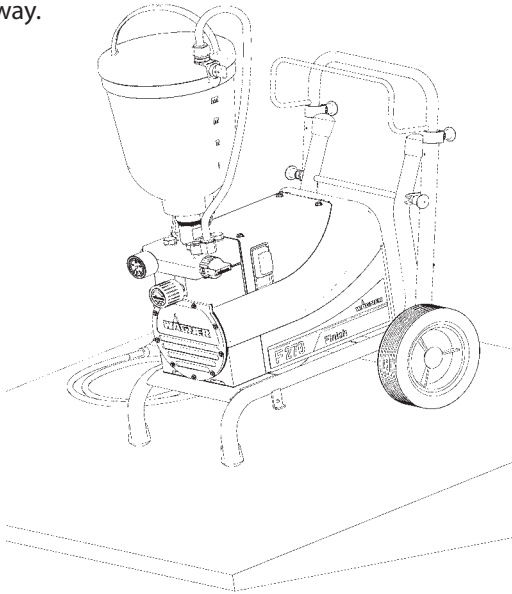

If possible do not use the unit on an inclined surface since the unit tends to wander through the resulting vibrations.

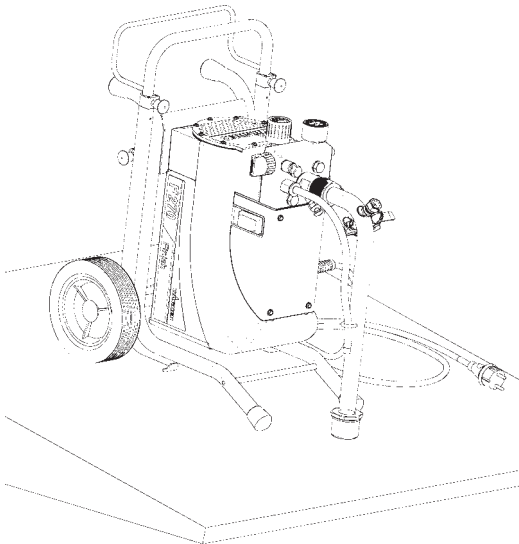

## 2 GENERAL VIEW OF APPLICATION

### 2.1 APPLICATION

Finish 370 / 250 is an electric driven unit for the airless atomization of different painting materials. Also it is able to feed the internal feeded paint roller, which is available as accessory.

Finish 370 /250 is made for jobs in the workshop and on the building site

The unit performance is conceived so that its use is possible on building sites for small- to middle-area dispersion work.

Finish 250 is designed for varnishing jobs. Small jobs with dispersion work are possible.

Both units are able for all common varnishing jobs like doors, door frames, balustrades, furniture, woodencladding, fences, radiators (heating) and steel parts.

### 2.2 COATING MATERIAL

Diluting lacquers and paints or those containing solvents, two-component coating materials, dispersion and latex paints.

No other materials should be used for spraying without WAGNER's approval.



Pay attention to the Airless quality of the coating materials to be processed.

The unit is able to process coating materials with up to 15,000 mPas. If highly viscous coating materials cannot be taken in or the performance of the unit is too low, the paint must be diluted in accordance with the manufacturer's instructions.



Attention: Make sure, when stirring up with motor-driven agitators that no air bubbles are stirred in. Air bubbles disturb when spraying and can, in fact, lead to interruption of operation.

#### 2.2.1 COATING MATERIALS WITH SHARP-EDGED ADDITIONAL MATERIALS

These particles have a strong wear and tear effect on valves and tips, but also on the heating hose and spray gun. This impairs the durability of these wearing parts considerably.

#### 2.2.2 FILTERING

Sufficient filtering is required for fault-free operation. To this purpose the unit is equipped with a suction filter (Item 1) and an insertion filter in the spray gun (Item 2). Regular inspection of these filters for damage or soiling is urgently recommended.

A high-pressure filter (Item 3) -available as accessory- is rising up the filtering surface and will make the work more comfortable.

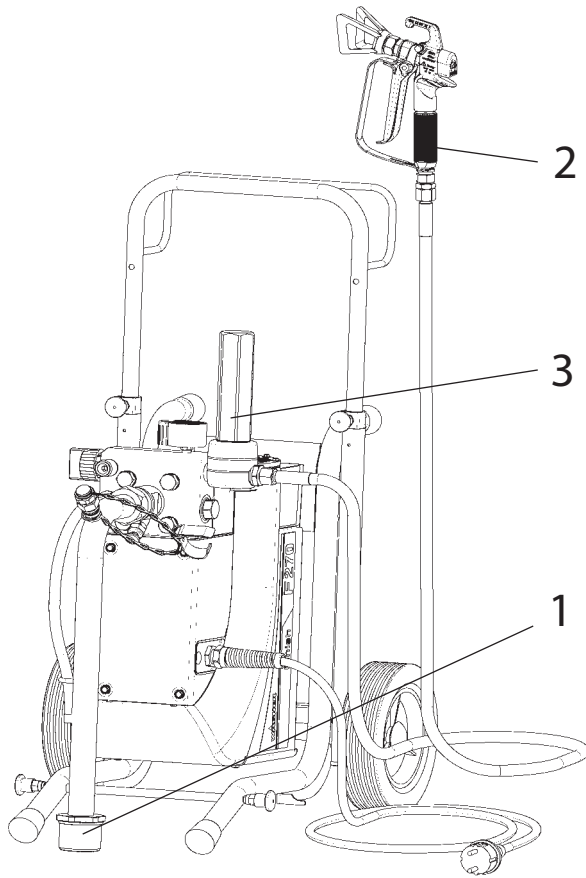

### 3. DESCRIPTION OF UNIT

#### 3.1 AIRLESS PROCESS

The main area of application are thick layers of highly viscous coating material.

At the Finish 370 / 250 unit a diaphragm pump takes in the coating materials and transports it via a high-pressure hose to the spray gun with the airless tip. Here the coating material atomizes since it is pressed through the tip core at a maximum pressure of 25 MPa (250 bar, 3625 psi). This high pressure has the effect of micro fine atomisation of the coating material. As no air is used in this process, it is described as an AIRLESS process.

This method of spraying has the advantages of finest atomisation, cloudless operation (depending of a correct unit adjustment) and a smooth, bubblefree surface. As well as these, the advantages of the speed of work and convenience must be mentioned.

#### 3.2 FUNCTIONING OF THE UNIT

The following section contains a brief description of the technical construction for better understanding of the function:

Finish 370 / 250 is an electrically driven high-pressure paint spraying equipment.

The motor (Item 1) drives directly the hydraulic pump. A piston (2) is moved up and down so that hydraulic oil is moved under the diaphragm (3) which then moves.

In detail:

The downwards movement of the machine opens the disk inlet valve (4) automatically and coating material is sucked in. During the upwards movement of the diaphragm, the coating material is displaced and the outlet valve opens while the inlet valve is closed.

The coating material flows under high pressure through the high-pressure hose to the spray gun and is atomized when it exists from the tip.

The pressure control valve limits the set pressure in the hydraulic oil circuit and thus also the pressure of the coating material.

A pressure change when the same tip is used also leads to a change in the amount of paint atomized.

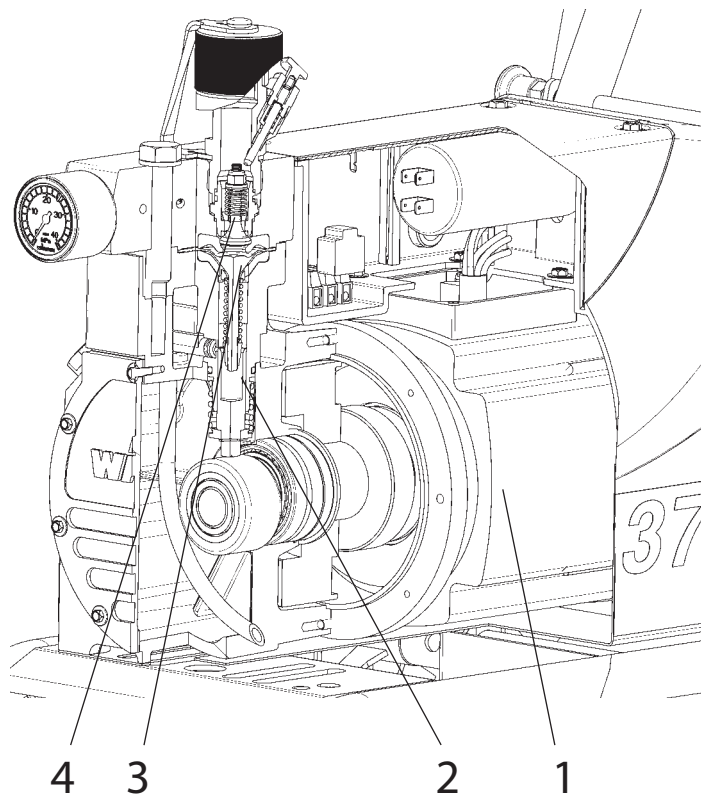

DESCRIPTION OF UNIT

**3.3 EXPLANATORY DIAGRAM**

- 1 Tip guard with airless tip
- 2 Spray gun
- 3 High-pressure hose
- 4 Connection for high-pressure hose
- 5 Pressure gage
- 6 Pressure control valve
- 7 Pressure relief valve

Symbols: Spraying  
 Circulation

- 8 ON / OFF switch
- 9 Return tube
- 10 Suction tube
- 11 Connection for cleaning with the spray gun
- 12 Hopper
- 13 Cleaning ring (TopClean) for hopper (accessory)
- 14 Inlet valve button
- 15 Outlet valve
- 16 Oil measuring stick under the oil screw plug

**3.4 TRANSPORTATION**

Unroll high-pressure hose and lay it over the shaft.

Pull the locking pins (Item 1) on both sides of shaft. The locking pins can be arrested by a small turn (left or right). Pull the shaft out and deblock the locking pins. A light pull or push will help to lock the pins well.

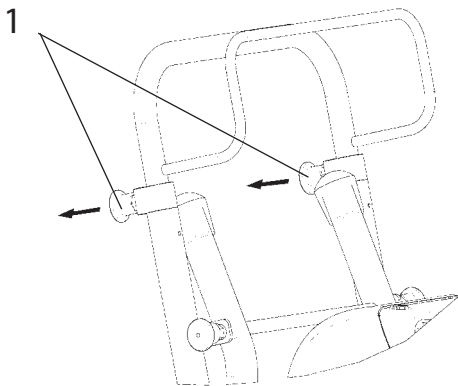

**Transportation in vehicle**

Secure the unit in the vehicle by means of suitable fasteners.

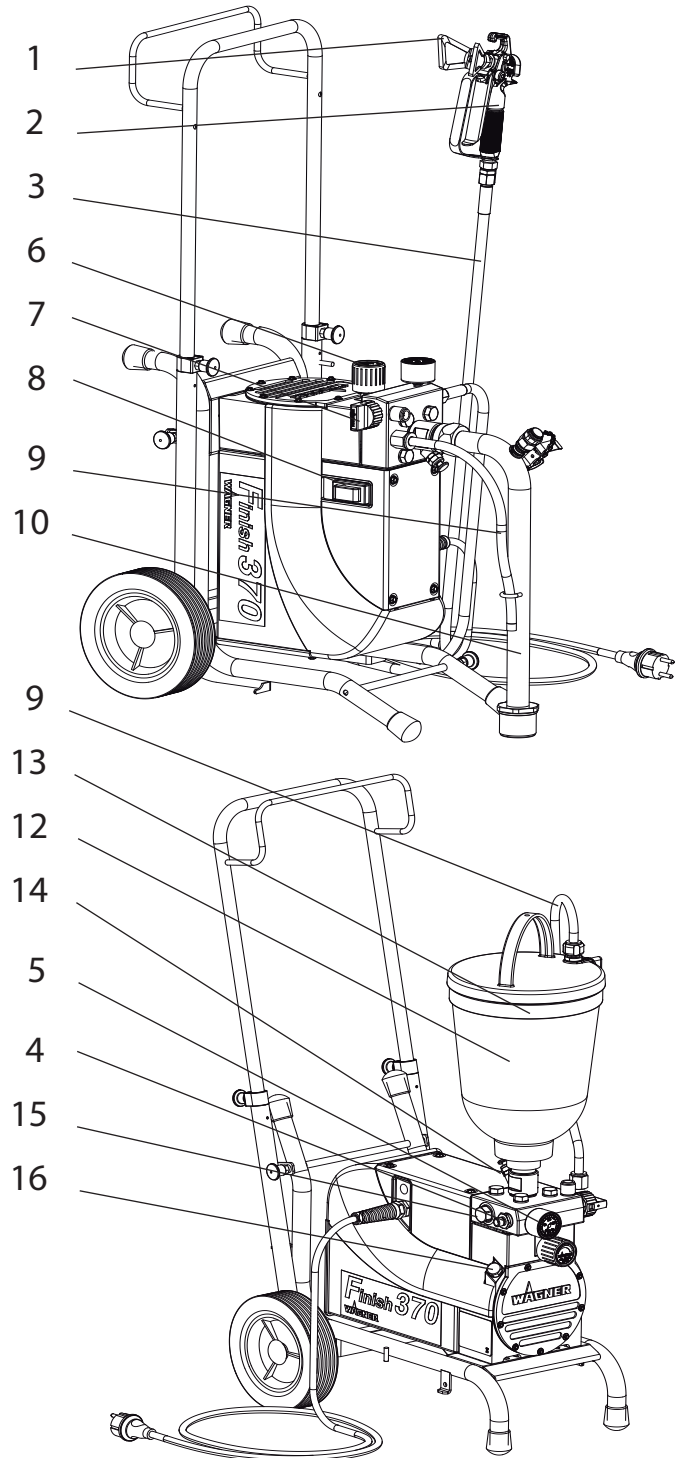

**3.5 TROLLEY BACKFITTING (ONLY FINISH 370)**

Pull locking pins (Item 1) on both sides of frame. The locking pins can be arrested by a small turn (left or right). Move frame into the other position. Deblock both locking pins so that they fit well in the rest position.



	<p>Before start with the backfitting, pull of main plug of socket, disassemble suction system and high pressure hose</p>
--	--

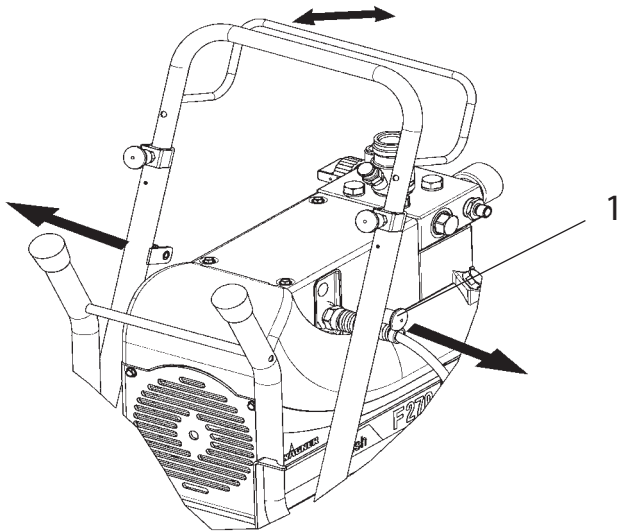

### 3.6 TECHNICAL DATA FINISH 250

Voltage :	230 V AC, 50 Hz
Fuses :	16 A time-lag
Unit connecting line :	6 m long, 3 x 1.5 mm <sup>2</sup>
Max. current consumption hose heating :	4,6 A
Degree of protection :	IP 54
Acceptance capacity :	1,1 kW
Max. operating pressure :	25 MPa (250 bar)
Max. volume flow :	2.2 l/min
Volume flow at 12 MPa (120 bar) with water :	1.8 l/min
Max. temperature of the coating material :	43 °C
Max. viscosity :	15,000 mPas
Empty weight pump :	28 kg
Hydraulic oil filling quantity :	0.65 liter
Max. vibration at the spraygun:	lower than 2.5 m/s <sup>2</sup>
Max. sound pressure level:	74 dB (A)*

\*Place of measurement: 1 m distance from unit and 1.60 m above floor, 12 Mpa (120 bar) operating pressure, reverberant floor

### 3.7 TECHNICAL DATA FINISH 370

Voltage :	230 V AC, 50 Hz
Fuses :	16 A time-lag
Unit connecting line :	6 m long, 3 x 1.5 mm <sup>2</sup>
Max. current consumption hose heating :	6.0 A
Degree of protection :	IP 54
Acceptance capacity :	1.3 kW
Max. operating pressure :	25 MPa (250 bar)
Max. volume flow :	2.9 l/min
Volume flow at 12 MPa (120 bar) with water :	2.3 l/min
Max. temperature of the coating material :	43 °C
Max. viscosity :	15,000 mPas
Empty weight pump :	29.5 kg
Hydraulic oil filling quantity :	0.65 liter
Max. vibration at the spraygun:	lower than 2.5 m/s <sup>2</sup>
Max. sound pressure level:	74 dB (A)*

\*Place of measurement: 1 m distance from unit and 1.60 m above floor, 12 Mpa (120 bar) operating pressure, reverberant floor

## 4 STARTUP

### 4.1 UNIT WITH SUCTION SYSTEM

1. Unscrew the dust protective cap (Item 1).
2. Ensure that the sealing surfaces of the connections are clean.  
Ensure that the red inlet (2) is inserted in the coating material inlet (5).
3. Use the enclosed 41 mm wrench to screw the union nut (3) at the suction hose (4) onto the coating material inlet (5) and tighten it.
4. Screw the union nut (6) at the return hose (7) to the connection (8) (22mm).

### 4.2 UNIT WITH UPPER HOPPER (5 LITRES)

1. Unscrew the dust protective cap (Item 1).
2. Ensure that the sealing surfaces of the connections are clean.  
Ensure that the red inlet (2) is inserted in the coating material inlet (5).
3. Screw the union nut (6) on the return pipe (7) onto the connection (8).
3. Hang the return pipe (7) into the hopper and screw the upper hopper (9) onto the coating material inlet (5).

**if using hopper with cleaning ring (TopClean) step 5 and 6**

5. Fix TopClean on hopper upside
6. Plug in return pipe into TopClean and screw on union nut

### 4.3 HIGH PRESSURE HOSE AND SPRAY GUN

1. Screw the high pressure hose (10) onto the hose connection
2. Screw the spray gun (11) onto the high pressure hose
3. Tighten all union nuts on high pressure hose so that no coating material can escape.
4. Screw the tip holder with the selected tip onto the spray gun, align tip and tighten union nut.

 <b>Attention</b>	When unscrewing the high pressure hose, hold firmly on the hose connection with a 22mm wrench.
---	--

### 4.4 CONNECTION TO THE MAINS NETWORK

 <b>Attention</b>	Connection must always be carried out via an appropriately grounded safety outlet with residual-current-operated circuit-breaker.
---	---

Before connecting the unit to the mains supply, ensure that the line voltage matches that specified on the unit's rating plate.

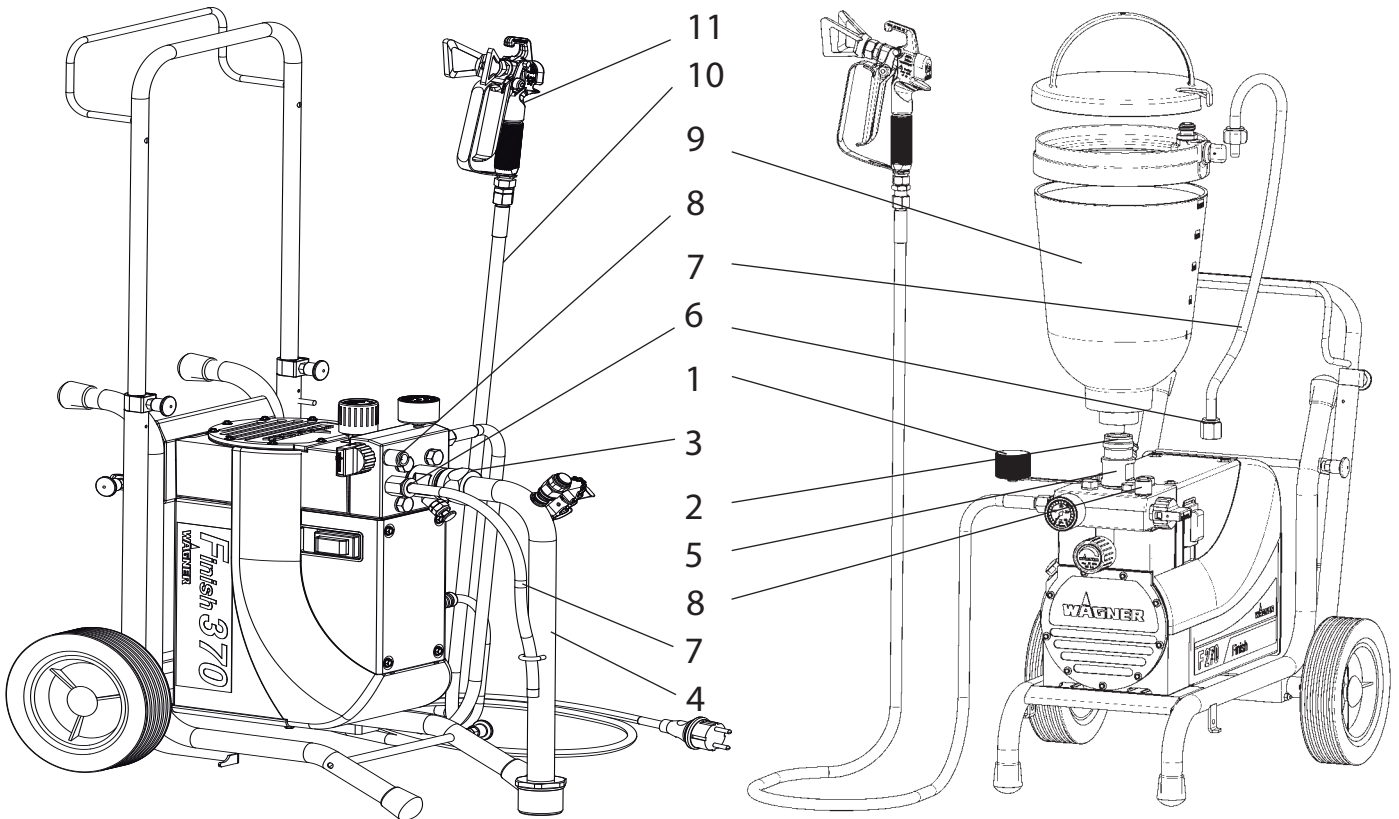



## 4.5 CLEANING PRESERVING AGENT WHEN STARTING-UP OF OPERATION INITIALLY

### Unit with suction tube

1. Immerse the suction system into a container filled with a suitable cleaning agent (recommendation: water).

### Unit with hopper

2. fill up hopper with a suitable cleaning agent (recommendation: water).
3. Switch on unit.
4. Turn the pressure regulating knob (1) to the **right** until the stop is reached.
5. Open relief valve (2) valve position  (circulation)
6. Wait until cleaning agent is emitted from the return hose.
7. Turn the pressure regulating knob (1) back approx. one rotation.
8. Close relief valve (2) valve position  (spraying), pressure is rising up inside the high pressure hose (visble at pressure gage)
9. Point the tip of the spray gun into an open collecting container and pull the trigger guard at the spray gun.
10. The pressure is increased by turning the pressure regulating knob (1) to the right. Set approx. 10 MPa at the pressure gage.
11. Spray the cleaning agent out of the unit for approx. 1 - 2 min. (~5 liters) into the open collecting container.

## 4.6 VENTILATE UNIT (HYDRAULIC SYSTEM) IF THE SOUND OF INLET VALVE IS NOT AUDIBLE

1. Switch on the unit.
2. Turn pressure regulating knob (1) **three revolutions** to the **left**.
3. Open relief valve (2) valve position  (circulation)  
The hydraulic system is ventilated. Leave the unit on for two or three minutes.
4. Then turn pressure regulating knob (1) to the **right** until stop.
5. Press inlet valve pusher (4).  
Sound of the inlet valve is audible.
6. If not, repeat points 2 and 4

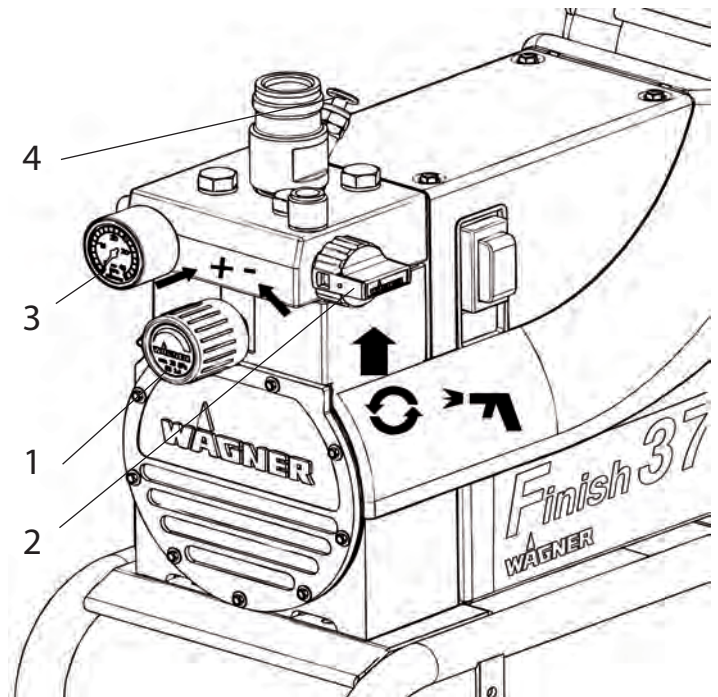



## 4.7 TAKING THE UNIT INTO OPERATION WITH COATING MATERIAL

### Unit with suction tube

1. Immerse the suction system into a container filled with coating material.

### Unit with hopper

2. fill coating material into the hopper.
3. Press inlet valve pusher (4) several times to release possibly clogged inlet valve
4. Open relief valve (2) valve position  (circulation)
5. Switch on unit.
6. Turn the pressure regulating knob (1) to the **right** until the stop is reached.  
When the noise of the valves changes, the unit is bled and takes in coating material.
7. If coating material exits from the return hose, turn the pressure regulating knob (1) back approx. 1 rotation.
8. Close relief valve (2) valve position  (spraying), pressure is rising up inside the high pressure hose (visble at pressure gage (3))
9. Pull of the spray gun and spray into an open collecting container in order to remove the remaining cleaning agent from the unit. When coating materials exits from the tip, close the spray gun.
10. Pull of the spray gun and adjust the spraying pressure by turning the pressure regulating knob (1).
11. The unit is ready to spray.

## 5 SPRAYING TECHNOLOGY

Move the spray gun evenly during the spraying process. If this is not observed, an irregular spraying appearance will be the result. Carry out the movement with the arm, not with the wrist. A parallel distance of approx. 30 cm between the tip and the surface to be coated should always be observed. The lateral limitation of the spray fan should not be too distinct. The edge of spraying should be gradual to facilitate overlapping of the next coat. The spray gun should always be held at an angle of 90° to the surface to be coated. A spray fan aimed obliquely at the surface to be coated leads to an unwanted spray cloud.

To achieve perfect surfaces at varnishing works, special accessories are available at Wagner, e.g. FineFinish tips or an AirCoat gun set. Your Wagner dealer will advise you.

## 6 HANDLING THE HIGH-PRESSURE HOSE

The high-pressure hose is to be handled with care. Avoid sharp bending or kinking. The smallest bending radius amounts to about 20 cm.

Do **not drive over** the high-pressure hose. Protect against sharp objects and edges.

 <b>Danger</b>	<p>Danger of injury through leaking high-pressure hose. Replace any damaged high-pressure hose immediately. Never repair defective high-pressure hoses yourself!</p>
---	--

	<p>When using the high-pressure hose while working on scaffolding, it is best to always guide the hose along the <b>outside</b> of the scaffolding.</p>
--	---

### 6.1 HIGH-PRESSURE HOSE

The unit is equipped with a high-pressure hose specially suited for diaphragm pumps.

	<p>Only use WAGNER original-high-pressure hoses with internal heating in order to ensure functionality, safety and durability.</p>
--	--

## 7 INTERRUPTION OF WORK

1. Turn pressure regulating knob **three revolutions** to the **left**.
2. Open relief valve (2) valve position  (circulation)
3. Switch off the unit
4. Pull trigger guard of spray gun to decrease the pressure of the high pressure hose and the spray gun.
5. Secure the spray gun, refer to the operating manual of the spray gun.
6. Remove tip from tip holder and store the tip in a small vessel with suitable cleaning agent.
7. Leave the suction system immersed in the coating material or immerse it in the corresponding cleaning agent. The suction filter and unit should not dry out.
8. Cover the material container in order to prevent the paint from drying.

	<p>In using quick-drying or two-component coating materials, do not fail to rinse unit through with a suitable cleaning agent during the processing period.</p>
--	---

## 8 CLEANING THE UNIT

A clean state is the best method of ensuring operation without problems. After you have finished spraying, clean the unit. Under no circumstances may coating material rests dry and harden in the unit. The cleaning agent used for cleaning (only with a flash point above 21 °C) must be suitable for the coating material used.

- **Secure the spray gun**, refer to the operating manual of the spray gun.  
Remove and clean the tip.
- **Unit with suction system**
  1. Open relief valve valve position (circulation) and switch on unit
  2. Remove suction tube from the material container, the return tube remains over the material container.
  3. Immerse the suction system into a container filled with a suitable cleaning agent
  4. Turn the pressure control valve back in order to set a minimal spraying pressure.
  5. Close relief valve, valve position (spraying)
  6. Pull the trigger guard of the spray gun in order to pump the remaining coating material from the suction hose, high-pressure hose and the spray gun into an open container (if appropriate, increase the pressure at the pressure control valve slowly in order to obtain a higher material flow).

	The container must be earthed in case of coating materials which contain solvents.
--	--

	Caution! Do not pump or spray in container with small opening (bunghole)! See safety regulations.
--	--

7. Open relief valve valve position (circulation)
8. Pump suitable cleaning agent in the circuit for several minutes.

**with inflexible suction system (tube) step 9 up to 17**

9. Screw the spray gun to the suction tube with both enclosed 22 mm wrenches.
10. Pump a suitable cleaning agent in the circuit for about 1 minute.
11. Pull the trigger guard of the spray gun and lock it with a clamp.
12. Close relief valve, valve position (spraying)
13. Clean the suction tube about 3 minutes long.

14. Rinse in the circuit – Open relief valve valve position (circulation).
15. Close the spray gun.
16. When cleaning with water repeat the procedure about 3 minutes long with clear water.
17. Remove spray gun from suction tube, close spray gun connection at suction tube with closure nut.

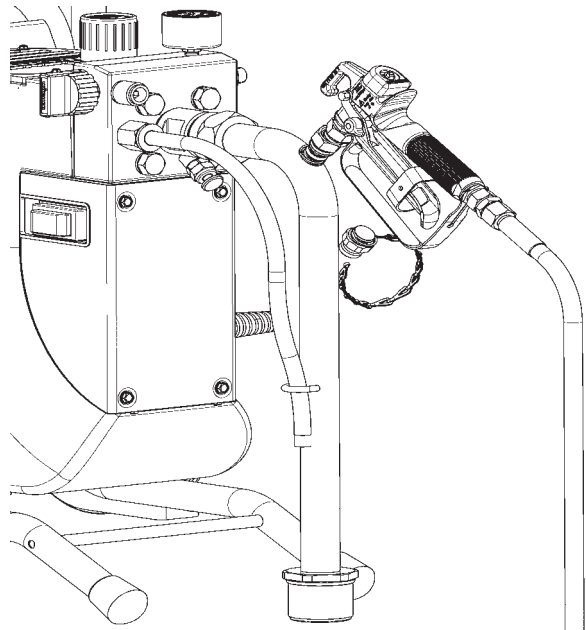

	The cleaning effect is increased by alternatively opening and closing the spray gun.
--	--

18. Close relief valve, valve position (spraying)
19. Pump the remaining cleaning agent into an open container until the pump is empty.
20. Switch off the unit

	Warm water improves the cleaning effect in the case of water-dilutable coating materials.
--	---

• **Unit with upper hopper**

1. Open relief valve valve position (circulation) and switch on unit
2. Turn the pressure control valve back in order to set a minimal spraying pressure.
3. Close relief valve, valve position (spraying)
4. Pull the trigger guard of the spray gun in order to pump the remaining coating material from the hopper, high-pressure hose and the spray gun into an open container (if appropriate, increase the pressure at the pressure control valve slowly in order to obtain a higher material flow).

## CLEANING THE UNIT

 <b>Attention</b>	The container must be earthed in case of coating materials which contain solvents.
----------------------	--

 <b>Attention</b>	Caution! Do not pump or spray in container with small opening (bunghole)! See safety regulations.
----------------------	---

5. Fill up hopper with suitable cleaning agent.
6. Open relief valve valve position (circulation)
7. Pump suitable cleaning agent in the circuit for several minutes.

**with cleaning ring (TopClean) step 8 up to 12**

8. Switch reverser knob into a horizontal position. The cleaning agent will flow around the circumference of the inner hopper wall and will clean it in some minutes, depending of the fouling
9. Switch reverser knob into the upright position. Cleaning agent is flowing directly into the hopper

 <b>i</b>	Do not switch the reverser knob at the cleaning ring into the horizontal position when the pump is load with coating material. The divider holes can be plugged. Than the cleaning work of cleaning ring is reduced, and it will take more time up to the cleaning ring has cleaned itself.
--------------	---

10. Close relief valve, valve position (spraying)
11. Pump the remaining cleaning agent from the hopper, high-pressure hose and the spray gun into an open container
12. Open relief valve valve position (circulation)
13. Switch off unit

**8.1 CLEANING THE UNIT FROM THE OUTSIDE**

 <b>Danger</b>	First unplug the power plug from the outlet.  Danger of short-circuits caused by water ingression! Never spray down the unit with high-pressure or high-pressure steam cleaners.
-------------------	--

Wipe down unit externally with a cloth which has been immersed in a suitable cleaning agent.

**8.2 SUCTION FILTER**

 <b>i</b>	Clean filters always ensure maximum volume, constant spray pressure and problem-free functioning of the unit.
--------------	---

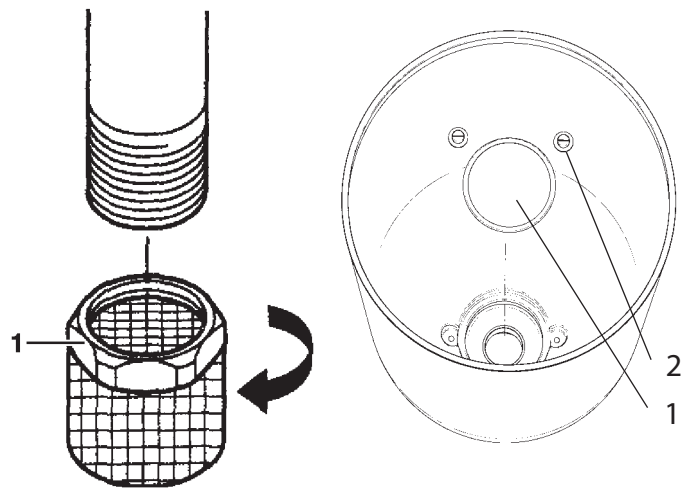

suction tube

5l hopper

Unit with suction system

1. Unscrew the filter (Item 1) from the suction tube.
2. Clean or replace the filter. Carry out cleaning with a hard brush and a corresponding cleaning agent.

Unit with hopper

1. Release screws with a screwdriver (Item 2).
2. Lift and remove filter disk with a screwdriver
3. Clean or replace the filter disk. Carry out cleaning with a hard brush and a corresponding cleaning agent.

**8.3 HIGH-PRESSURE FILTER**

1. Open relief valve valve position (circulation) - Switch the unit off.
2. Open the high-pressure filter and clean the filter insert. To do so:
3. Unscrew the filter housing (1) by hand.
4. Remove the filter insert (2) and pull out the bearing spring (3).
5. Clean all the parts with the corresponding cleaning agent. If compressed air is available – blow through the filter insert and bearing spring.
6. When mounting the filter ensure that the bearing ring (4) in the filter insert is positioned correctly and check the O-ring at the filter housing for damage.
7. Screw on the filter housing by hand until it stops (a higher tightening force only impedes later dismantling).

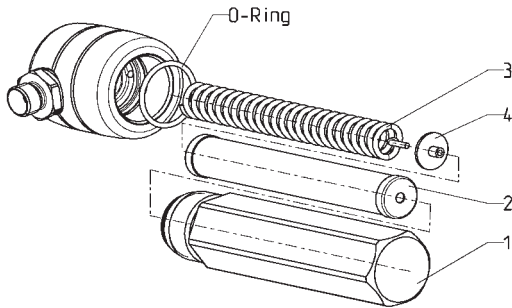

### 8.4 CLEANING THE AIRLESS SPRAY GUN

1. Rinse the Airless spray gun with a suitable cleaning agent under lower operating pressure.
2. Clean the tip thoroughly with a suitable cleaning agent so that no suitable coating material rests remain.
3. Do not store the tip in solvent because this reduces the durability considerably.
4. Clean the outside of the Airless spray gun thoroughly.

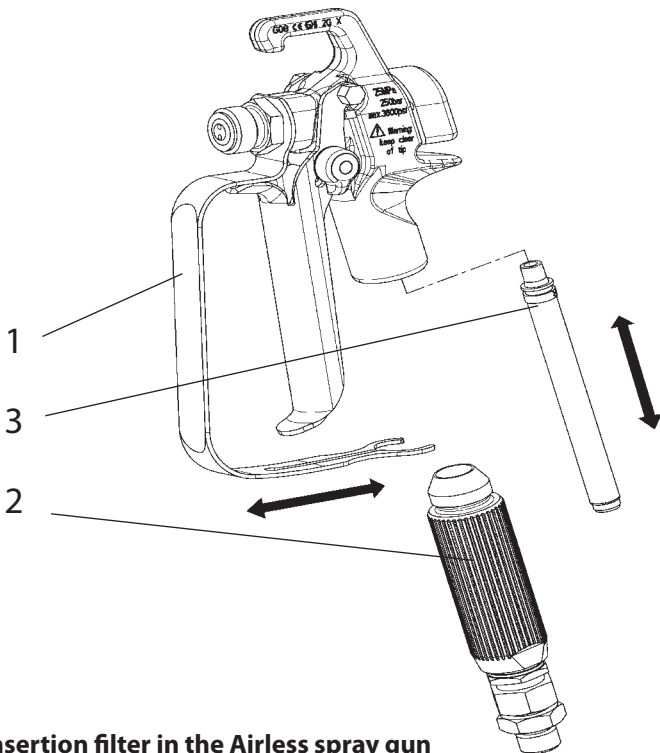

#### Insertion filter in the Airless spray gun

##### Removal

1. Pull the protective bracket (1) forwards.
2. Screw the grip (2) out of the gun housing. Pull out the insertion filter (3).
3. If the insertion filter is clogged or defective, replace it.

##### Installation

1. Slide the insertion filter (3) with the longer cone into the gun housing.
2. Screw the grip (2) into the gun housing and tighten it.
3. Latch in the protective bracket (1).

## 9 SERVICING

### 9.1 GENERAL SERVICING

	An annual expert check is highly recommended to be sure to have a safe unit
--	---

	You can servicing of the unit carried out by the Wagner Service. Favorable conditions can be agreed with a service agreement and/or maintenance packages.
--	---

#### Minimum check before every startup:

1. Check the high-pressure hose, spray gun with rotary joint, power supply cable with plug for damage.
2. Check whether the pressure gage can be read.

#### check at periodical intervals:

1. Check inlet-, outlet-, relief valve according wear. Clean it and replace worn out parts.
2. Check all filter inserts (spray gun, suction system) clean it and replace if necessary.

### 9.2 HIGH-PRESSURE HOSE

Inspect the high-pressure hose visually for any notches or bulges, in particular at the transition in the fittings. It must be possible to turn the union nuts freely. A conductivity of less than 1 MΩ must exist across the entire length.

	Have all the electric tests carried by the Wagner Service.
--	--

Attention

## 10 REPAIRS AT THE UNIT



Switch the unit off.  
Before all repair work: Unplug the power plug from the outlet.

### 10.1 INLET VALVE PUSHER

1. Use a 17 mm spanner to screw out the inlet valve button.
2. Replace the wiper (1) and O-ring (2).

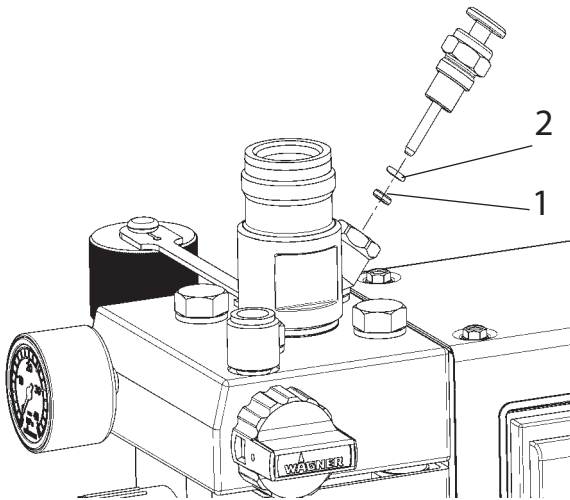

### 10.2 INLET VALVE

1. Place the enclosed 30 mm wrench on the trigger housing (1).
2. Loosen the trigger housing (1) with light blows of a hammer on the end of the wrench.
3. Screw out the trigger housing with the inlet valve (2) from the paint section.
4. Pull off the clasp (3) using the enclosed screwdriver.
5. Place the enclosed 30 mm wrench on the inlet valve (2). Turn out the inlet valve carefully.
6. Clean the valve seat (4) with a cleaning agent and brush (ensure that no brush hairs are left behind).
7. Clean the seals (5, 6) and check for damage. Replace, if necessary.
8. Check all the valve parts for damage. In case of visible wear replace the inlet valve.

### Installation

1. Insert the inlet valve (2) into the trigger housing (1) and secure with the clasp (3). Ensure that the (black) seal (5) is mounted in the trigger housing.
2. Screw the unit from the trigger housing and the inlet valve into the paint section. The same (black) seal (7) has to be mounted in the paint section.
3. Tighten the trigger housing with the 30 mm wrench and tighten with three light blows of the hammer on the end of the wrench. (Corresponds to approx. 90 Nm tightening torque).

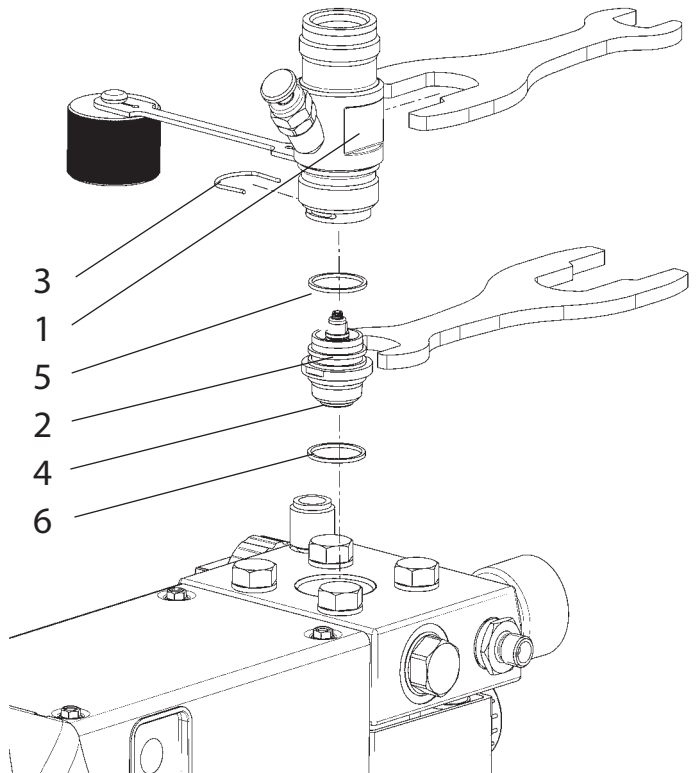

### 10.3 OUTLET VALVE

1. Use a 22 mm wrench to screw the outlet valve from the paint section.
2. Carefully pull off the clasp (1) using the enclosed screwdriver. The compression spring (2) presses ball (4) and valve seat (5) out.
3. Clean or replace the components.
4. Check the O-ring (7) for damage.
5. Check the installation position when mounting the spring support ring (3) (clipped onto spring (2)), outlet valve seat (5) and seal (6), refer to figure.



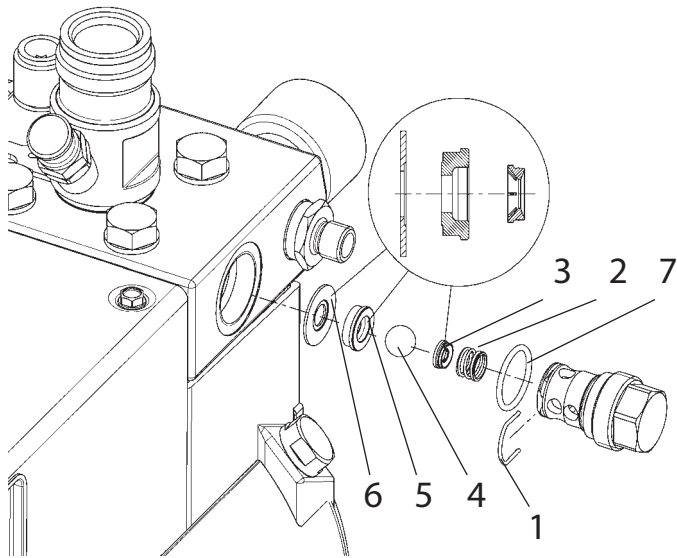

### 10.4 PRESSURE CONTROL VALVE



Only have the pressure control valve (1) replaced by the customer service.  
The max. operating pressure has to be reset by the customer service.

### 10.5 RELIEF VALVE

Replace a fault relief valve (1) as a single unit.  
Only the O-ring (2) may be replaced as a single part

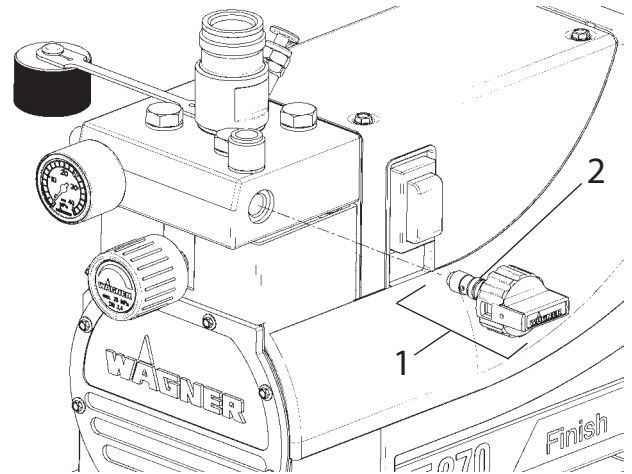

### 10.6 REPLACING THE DIAPHRAGM



Switch the unit off.  
Before all repair work: Unplug the power plug from the outlet.

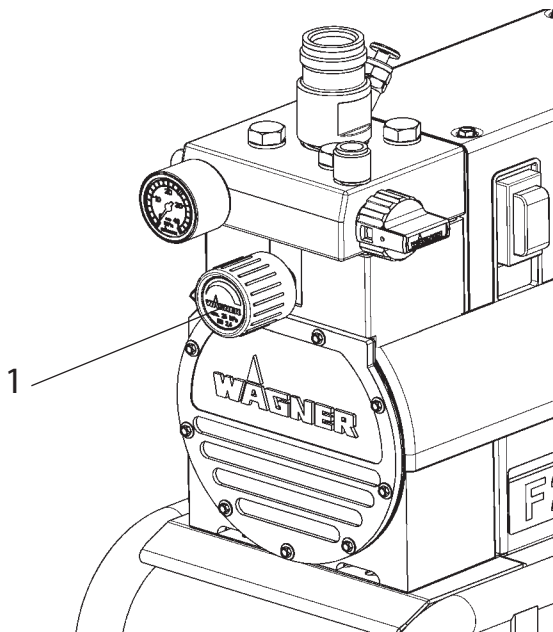

2. Screw the trigger housing with inlet valve out of the paint section as described in Section 10.2 Inlet valve, Items 1 to 3. (disassembling of hexagon nuts will become easier)
3. Turn back the pressure control valve, rotary knob completely (anti-clockwise).  
(Note: If the unit is still warm, open the oil screw plug (6) briefly in order to compensate the pressure and close it again.)
4. Use a 19 mm wrench to screw the hexagonal bolt (Item 1) out of the pressure insert (2).
5. Remove the paint section (3).
6. Remove the insert (4) and the diaphragm (5).
7. The diaphragm can only be used once. Always replace the diaphragm.

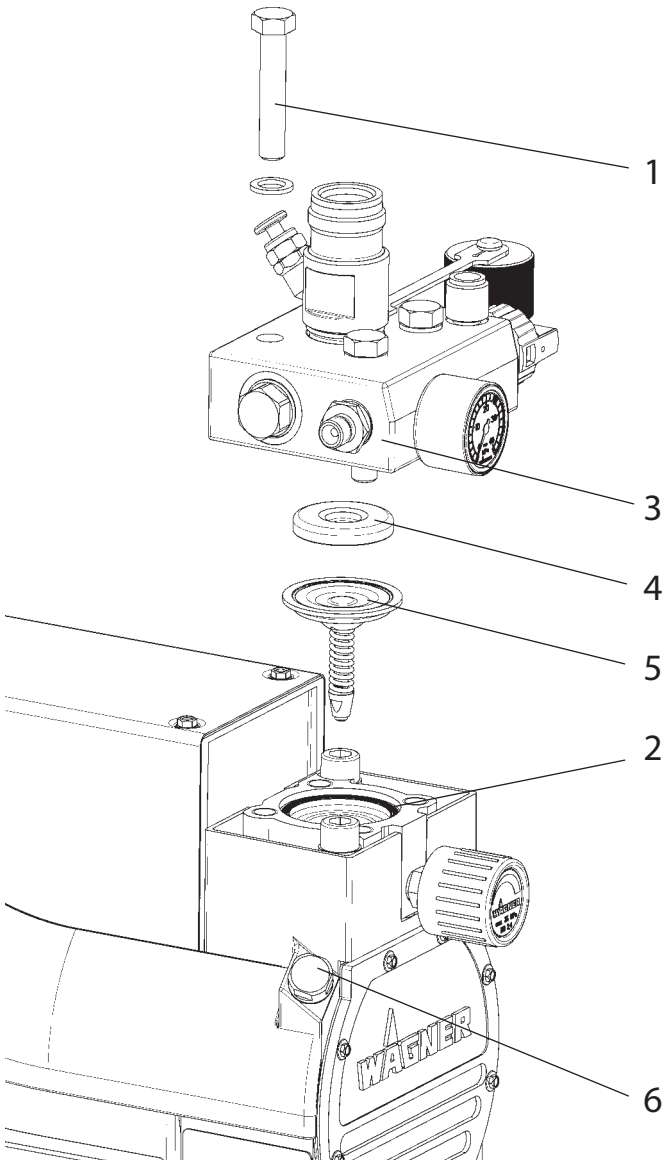

Before mounting the new diaphragm, clean the insert as well as the grooved surface at the pressure insert (2) and the paint section (3) and wipe off any oil.

**Mounting is carried out in the reverse order.**

1. First tighten all the hexagonal bolts (1) crosswise with 30Nm, then crosswise with 70Nm.
2. Before starting up leave the pressure control valve in the open position for about 2 minutes while the motor is running (bleeds the unit). Only then close it until the noise of the inlet valve can be heard.

**10.7 REPLACING THE POWER CABLE**

	<p>Switch the unit off. Before all repair work: Unplug the power plug from the outlet.</p>
--	--

1. Remove the cover (1) (a screwdriver may be helpful to move the cover back from the box).
2. Loosen the cable threaded joint (2).
3. Loosen the wires in the mains terminal (3).
4. Replace the unit connecting line.  
(only an approved power cable with the designation H07-RNF with a splash-proof plug may be used).
5. Connect the green/yellow wire to the contact with the PE sign.
6. Connect the cover again with the earthing plug for the heating hose and mount it carefully (do not squeeze any cables!)

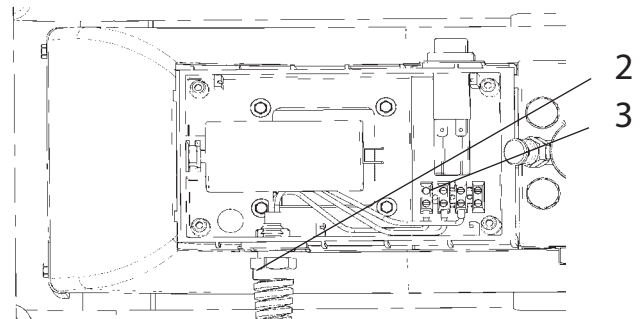
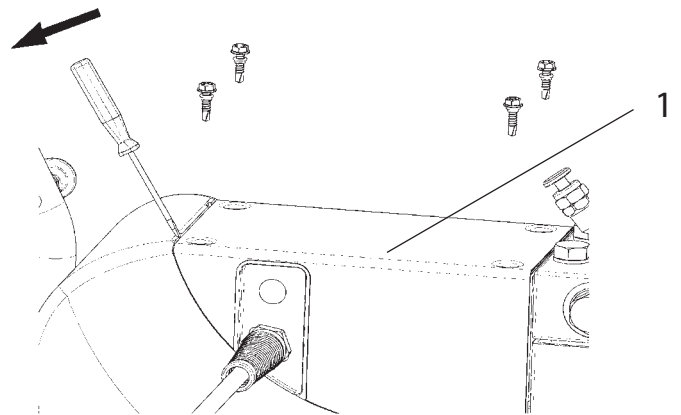

**10.8 TYPICAL WEAR PARTS**

Despite the use of high-quality materials the highly abrasive effect of the paints means that wear can occur at the following parts:

**Inlet valve** (spare part Order No.: 0344700)

For replacing refer to Section 10.2

(failure becomes noticeable through performance loss and/or poor or no suction)

**Outlet valve** (spare part Order No.: 0341702)

For replacing refer to Section 10.3

(failure becomes noticeable through performance loss and/or poor suction) The outlet valve is usually considerably more durable than the inlet valve. Thorough cleaning may already help here.

**Relief valve** (spare part Order No.: 0169248)

For replacing refer to Section 10.5

(failure is noticeable through performance loss. Furthermore material arrives constantly at the return hose although the multifunction switch is set to spraying.

This part is relatively seldom a wear part.

10.9 CONNECTION DIAGRAM

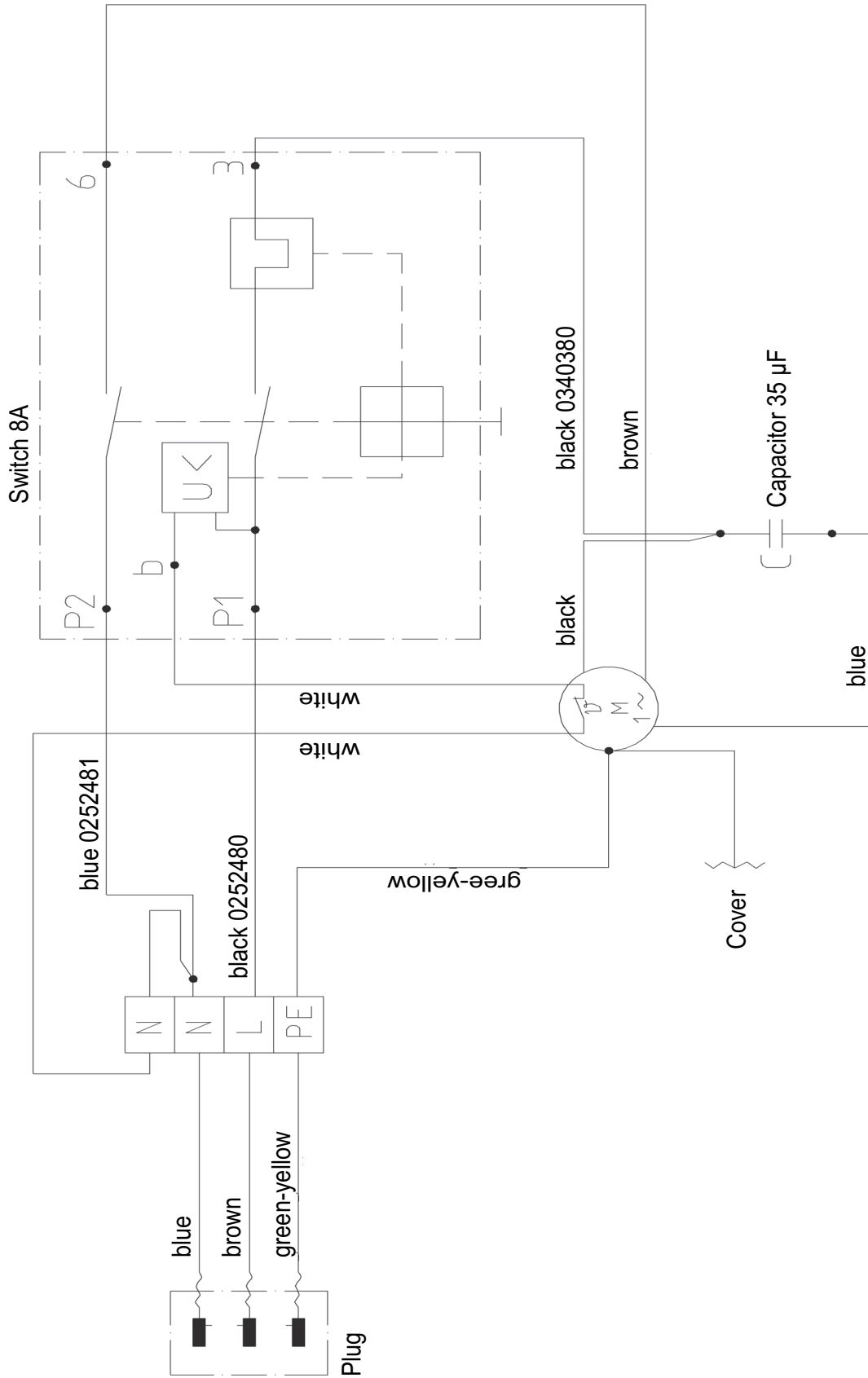

### 10.10 REMEDY IN CASE OF FAULTS

TYPE OF MALFUNCTION	WHAT ELSE?	POSSIBLE CAUSE	MEASURES FOR ELIMINATING THE MALFUNCTION
Unit does not start	Motor switch can not switched on	No voltage applied	Check voltage supply
		Unit fuse has triggered	Let the motor cool down
Unit does not suck in	Air bubbles exit from the return hose	Unit is sucking in outside air	Check: Suction system tightened properly? Cleaning connection at rigid suction tube screwed tight and not leaking? Inlet valve button leaky? -> Replace wiper and O-ring (-> refer to Section 10.1)
	Air bubbles do not exit at the return hose	Inlet valve clogged	Press the inlet valve button until the stop is reached several times by hand
		Inlet/outlet valve soiled / foreign bodies (e.g. threads) drawn in / worn	Remove the valves and clean then (-> refer to Section Pkt.10.2/10.3) / replace worn parts
		Pressure control valve turned down completely	Turn the pressure control valve to the right until the stop is reached
Unit does not generate pressure	Unit has sucked in	Air in the oil circuit	Bleed the oil circuit in the unit by turning the pressure control valve completely to the left (until overturning) and let it run approx. 2 – 3 min. Then turn the pressure control valve to the right and set the spraying pressure (repeat process several times, if necessary). Process is assisted by positioning the unit vertically.
	Unit reached pressure, but the pressure collapses, also at the pressure gage, during spraying.	Suction filter clogged	Check the suction filter. If necessary, clean/ replace
		Paint cannot be worked in this state. Due to its properties the paint clogs the valves (inlet valve) and the delivery rate is too low.	Dilute the paint
	Unit reached pressure, but the pressure collapses during spraying. pressure gage still shows high pressure	Clogged filter do not let enough paint pass	Check/clean the (high-pressure filter) gun filter
		Tip clogged	Clean the tip (-> refer to Section 10.1)
	Unit does not generate the max. pressure possible. Paint nevertheless exits at the return hose.	Relief valve defective	Clean or replace the relief valve (-> refer to Section 10.5)

## 11 SPARE PARTS AND ACCESSORIES

### 11.1 FINISH 370 / 250 ACCESSORIES

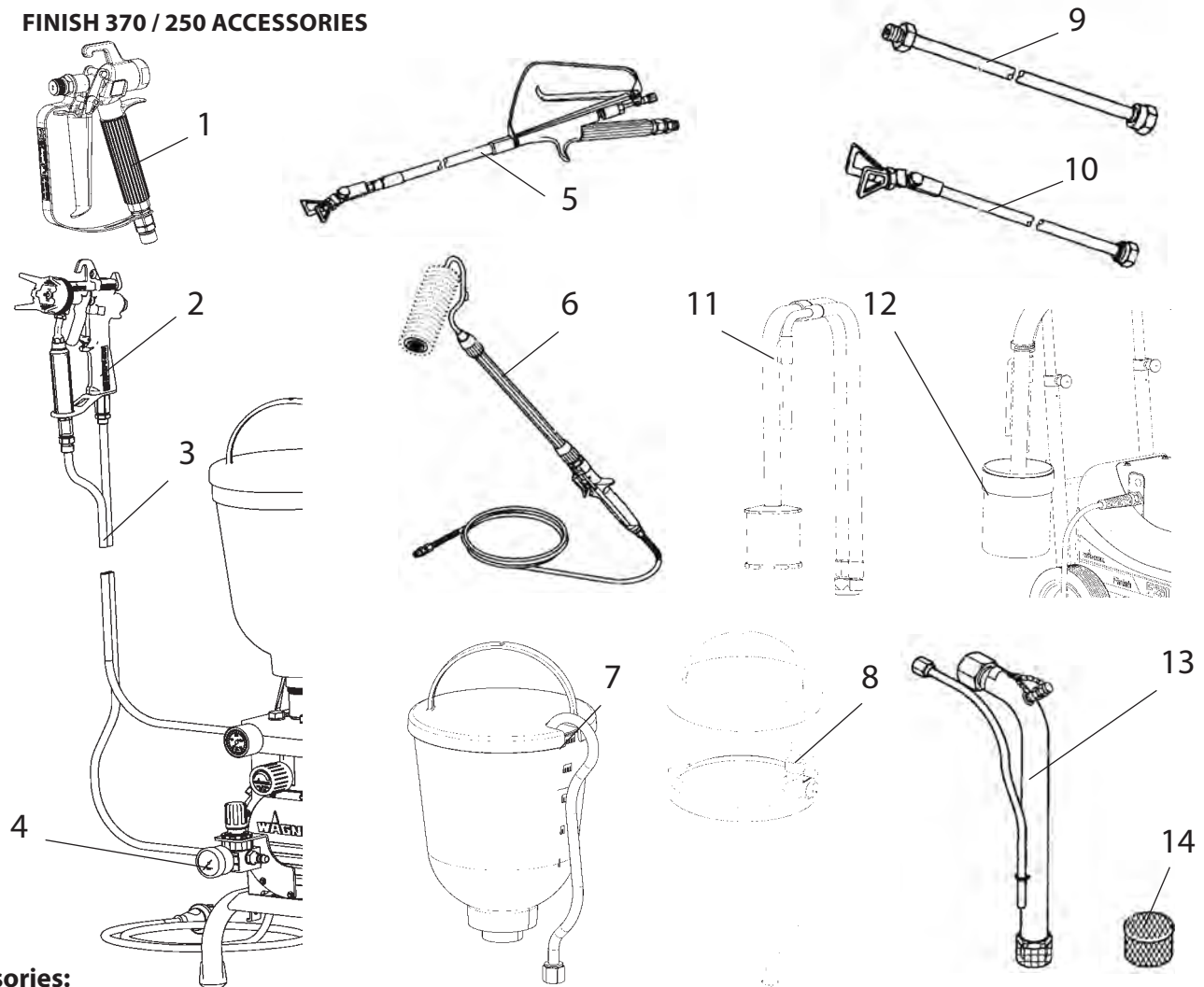

**Accessories:**

ITEM	DESIGNATION	ORDER NO.
1	Spray gun AG-14 (stainless steel) Spray gun AG-08 (aluminium made)	0502 166 0296 388
2	AirCoat spray gun GM-3000	0364 005
3	Double hose HP hose DN-3, 7.5 m	9984 564 9984 583
4	AirCoat-controler set	0252 910
5	Pole gun Length 100 cm Length 150 cm Length 370 cm	0096 019 0096 005 0096 006
6	Inline Roller	0345 010
7	Hopper 5l	0341 265
8	Hopper cleaning ring (TopClean)	0340 930

ITEM.	DESIGNATION	ORDER NO.
9	Tip extension Length 15 cm Length 30 cm Length 45 cm Length 60 cm	0556 051 0556 052 0556 053 0556 054
10	Tip extension with Sleuable knee joint Length 100 cm Length 200 cm Length 300 cm	0096 015 0096 016 0096 017
11	Suction system (flexible) for dispersionen	0034 630
12	Cleaning container for suction system Holder for container (only F250)	0055 553 0252 264
13	Suction system (rigid) for dispersi- onon	0341 264
14	Filter bag, mesh width 0,3 mm	0097 531

**11.2 SPARE PARTS LIST PUMP HEAD**

ITEM	ORDER-N0	DESIGNATION
1	0252 290	Pump head
2	0252 442	Pressure insert D18 (Finish 370)
2	0252 443	Pressure insert D16,5 (Finish 250)
3	0252 440	Piston D18 (Finish 370)
3	0252 441	Piston D16,5 (Finish 250)
4	0187 308	Spring plate
5	9922 516	Snap ring 12x1
6	0005 311	Pressure spring
7	3050 916	O-ring 25x3
8	0252 289	Diaphragm with inlet
9	9971 395	O-ring 10x1,25
10	0169 248	Refief valve (item 9,10)
11	0341 702	Outlet valve, service set
12	0252 469	Outlet valve housing
	0252 470	End part (to order with item12)
13	0344 700	Inlet valve
14	0341 331	Sealing ring (2x)
15	0252 279	Trigger housing
16	0341 336	Clasp
17	0340 339	Inlet
18	9990 865	Dust protective cap M36x2
19	0341 241	Inlet valve button (item19, 20, 21)
20	0341 316	Wiper
21	9971 486	O-ring 4x2 (FFPM)
22	0047 432	Double socket 1/4" NPS/M16x1,5
23	9970103	Sealing ringg
24	0252 475	Pressure gage
25	0252 478	Cap
26	9970 218	Sealing ring
27	0252 295	Suction pipe
28	0252 294	Pressur control valve (item 28, 29)*
29	9971 365	O-ring 9,25x1,78*
30	0010 861	Pressure spring*
31	0010 859	Stop sleeve*
32	0010 858	Clip*
33	0158 250	Pressure regulating knob*

34	9951 072	Cap
35	0252 493	Label, plate
36	0158 383	Label Wagner
37	9993 105	Hose nozzle M5
38	3051 678	O-ring 9x3
39	0252 316	Return pipe
40	9900 217	Hexagon head screw M12x90 (4)
41	9906 035	Cylinder head screw M12x50 (2)
42	9920 204	Washer 13 (6)

\* When these parts are replaced the operating pressure has to be set again by the customer service.

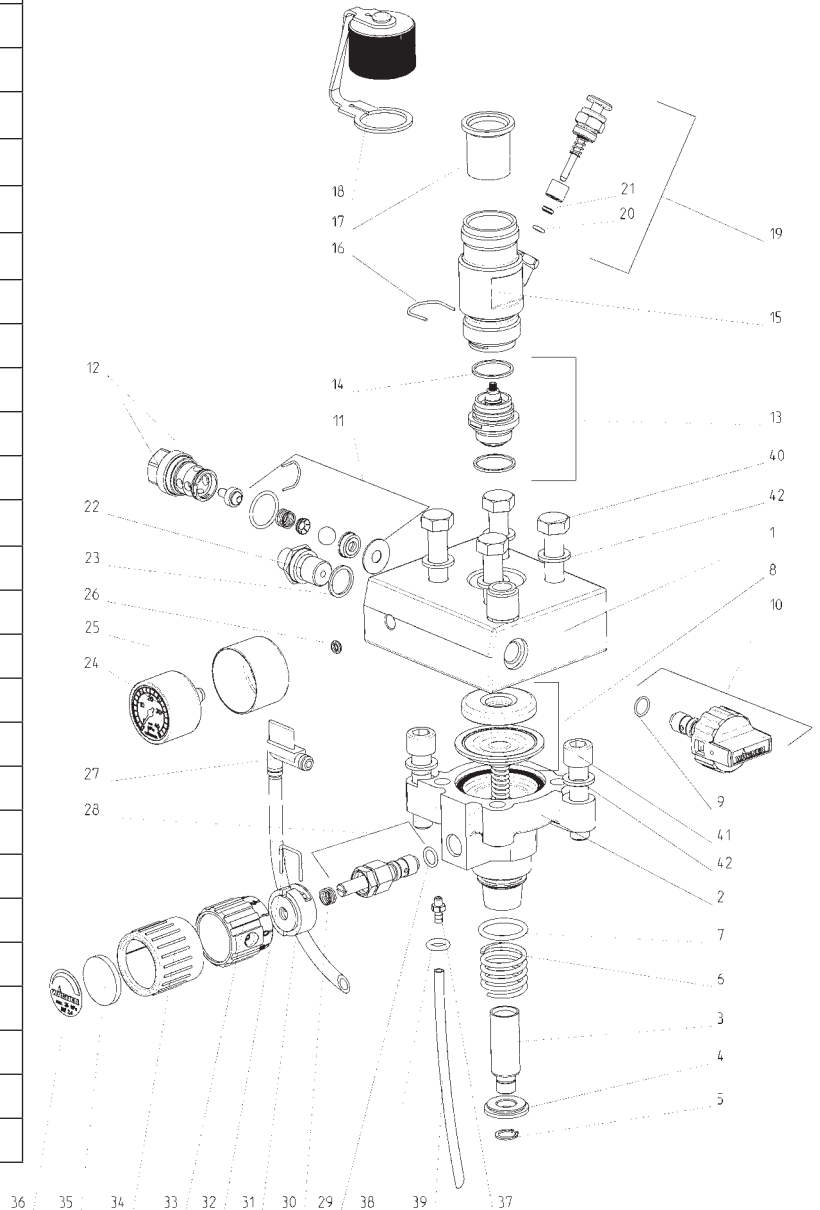

**Spare parts diagram pump head**

### 11.3 SPARE PARTS LIST PUMP-AGGREGATE

ITEM	ORTDER-NO	DESIGNATION
1	0252 280	Motor assy. (item 1 to 10)
2	0252 431	Flange ring
3	3057 379	O-ring 30x2,5
4	0252 429	Inner ring
5	9922 603	Snap ring 52x2
6	0252 428	Shaft sealing ring
7	0252 430	Needle bearing
8	0252 450	Housing
9	0252 432	Fan
10	0252 433	Fan cowl
11	0340 354	Gasket
12	0252 435	Frame, fan
13	9903 348	Hex self drilling screw (8)
14	9971 536	sealing disk (4)
15	9900 248	Hex washer head screw M4x12 (13)
16	9900 313	Cylinder head screw M8x25 (2)
17	9920 102	Washer 8,4 (2)
18	9900 249	Hex washer head screw M5x12 (4)
19	9904 306	Screw plug BSP 1/8"
20	9970 127	Sealing ring
21	0252 453	Oil cap screw
22	9971 146	O-ring
23	0252 452	Oil dipstick
24	0252 351	Front cover
25	0252 305	Seal
26	9960 429	Roller bearing
27	0252 385	Gasket
28	9953 696	Motor protection switch
29	0252 434	Electric box
30	0252 504	Label F370
	0252 502	Label F250 (left)
	0252 503	Label F250 (right)
31	9952 876	Capacitor 35µF
32	0341 520	Mains cable H07RN-F3G1.5 6m long
33	9952 685	Cable threaded joint M20x1,5
34	9952 686	Hexagon nut M20x1,5

35	9990 571	Plug (2)
36	9950 244	Terminal strip
37	0252 293	Cover

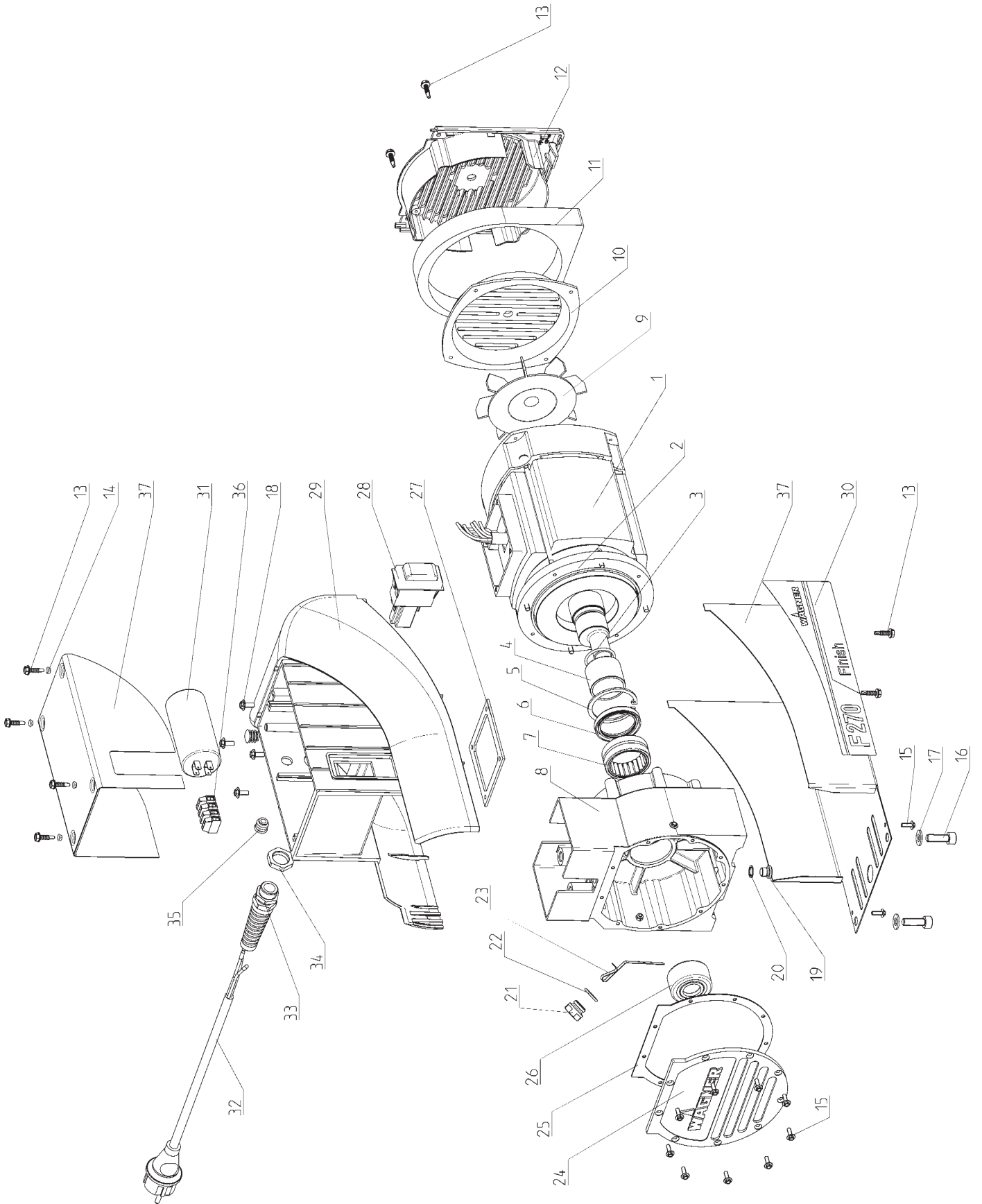

Spare parts diagram pump-aggregate



### 11.4 SPARE PARTS LIST HIGH-PRESSURE FILTER

ITEM	ORDER NO.	DESIGNATION
1	0097 121	High-pressure filter HF- 01 compl.
2	0097 301	Filter block
3	0097 302	Filter housing
4	0097 303	Hollow screw
5	0097 304	Seal ring
6	9970 110	Seal ring
7	9974 027	O-ring 30x2 (PTFE)
8	9971 401	O-ring 16x2 (PTFE)
9	0508 749	Bearing spring
10	0508 603	Bearing ring
11	0508 748	Filter insert 60 meshes
	0508 450	Optional: Filter insert 100 meshes
	0508 449	Filter insert 30 meshes
12	9994 245	Pressure spring

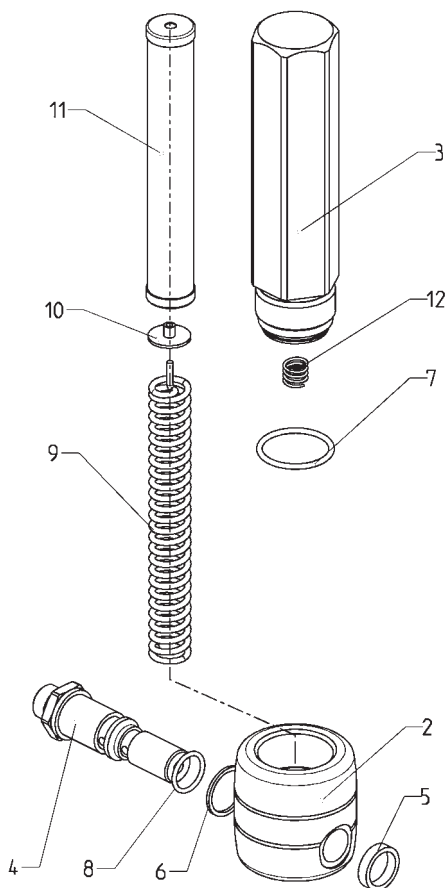

Spare parts diagram high-pressure filter

### 11.5 SPARE PARTS LIST TROLLEY

ITEM	ORDER-NO.	DESIGNATION
1	0252 291	Trolley assy. (for F-370)
2	9994 961	Wheel (2)
3	9994 950	Wheel cap (2)
4	0252 455	Locking pin (4)
5	0252 454	Spacer ring (2)
6	9910 106	Hexagon nut M5 (4)
7	0252 464	Sheet (2)
8	9900 142	Hexagon screw M5x12 (4)
9	9990 861	Plug (6)
10	9990 866	Rubber cap (4)

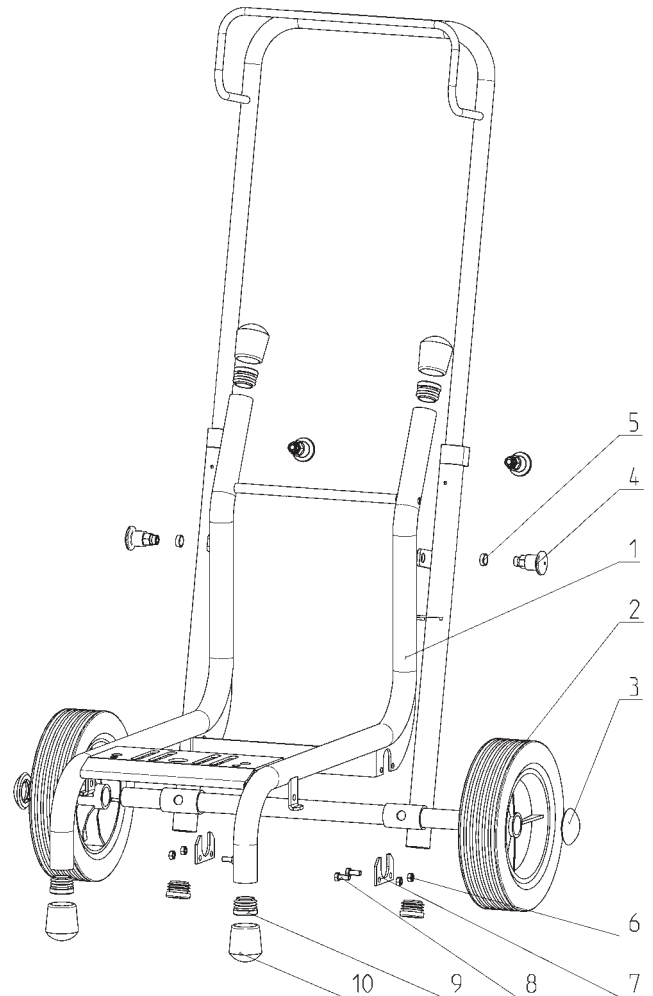

Spare parts diagram trolley F-370

SPARE PARTS AND ACCESSORIES

ITEM	ORDER-NO	DESIGNATION
1	0252 292	Trolley assy. (for F-250)
2	9994 961	Wheel (2)
3	9994 950	Wheel cap (2)
4	0252 455	Locking pin (4)
5	9990 861	Plug (2)
6	9990 866	Rubber cap (2)

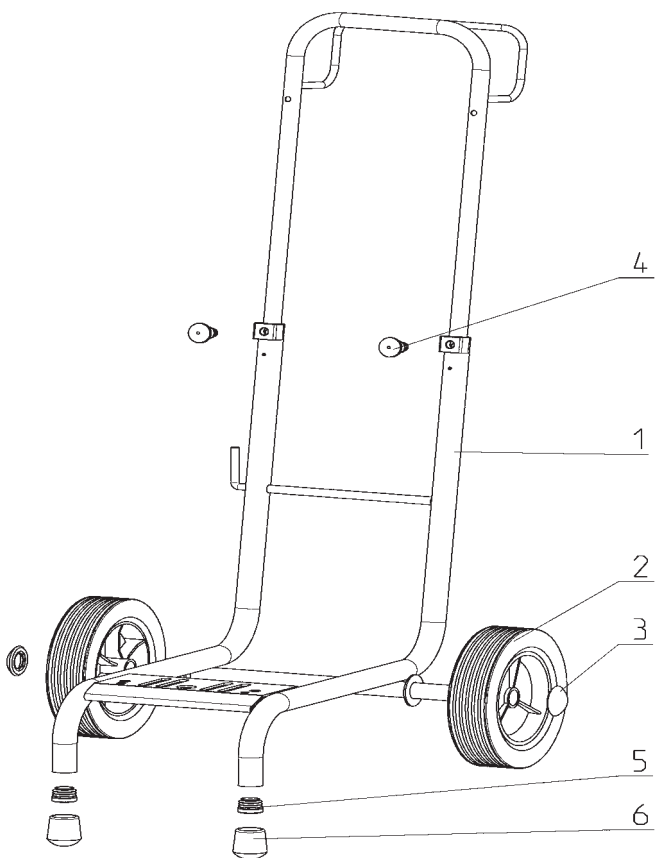

Spare parts diagram trolley F-250

**11.6 SPARE PARTS LIST SUCTION SYSTEM (RIGID)**

ITEM	ORDER-NO	DESIGNATION
1	0341 264	Suction system assy..
2	0344 341	Filter, mesh width 1 mm
	0250 245	Optional: Filter, mesh width 0,8 mm
3	0341 275	Return pipe
4	0341 260	Hex screw cap with chain and clamp
5	0341 367	Sealing

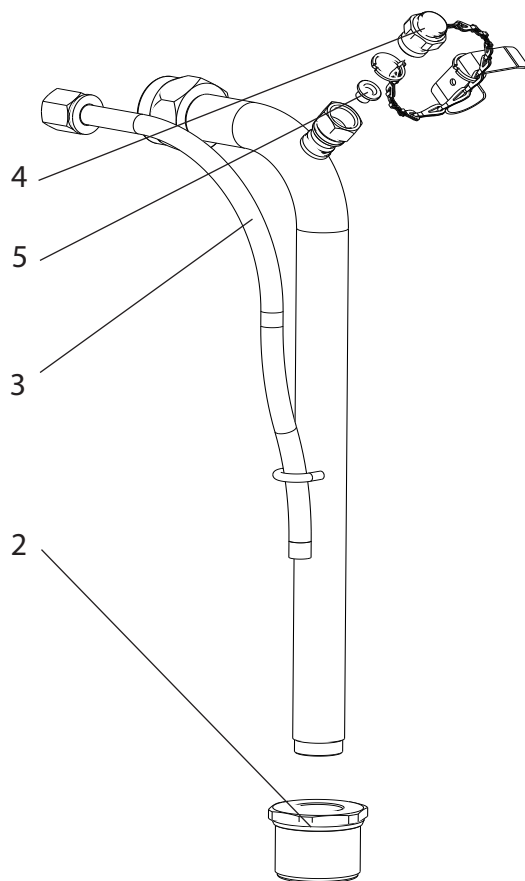

Spare parts diagram suction system (rigid)



### 11.7 SPARE PARTS LIST HOPPER 5L

ITEM	ORDER-NO	DESIGNATION
-	0341 265	Hopper 5l, assy.
1	0340 901	Cover
2	0037 607	Filter disk, mesh width 0,8 mm
	0003 756	Optional: Filter disk, mesh width 0,4 mm
3	9902 306	Sheet metal screw 3,9x13 (2)
4	0340 904	Hopper
5	0340 908	Return pipe

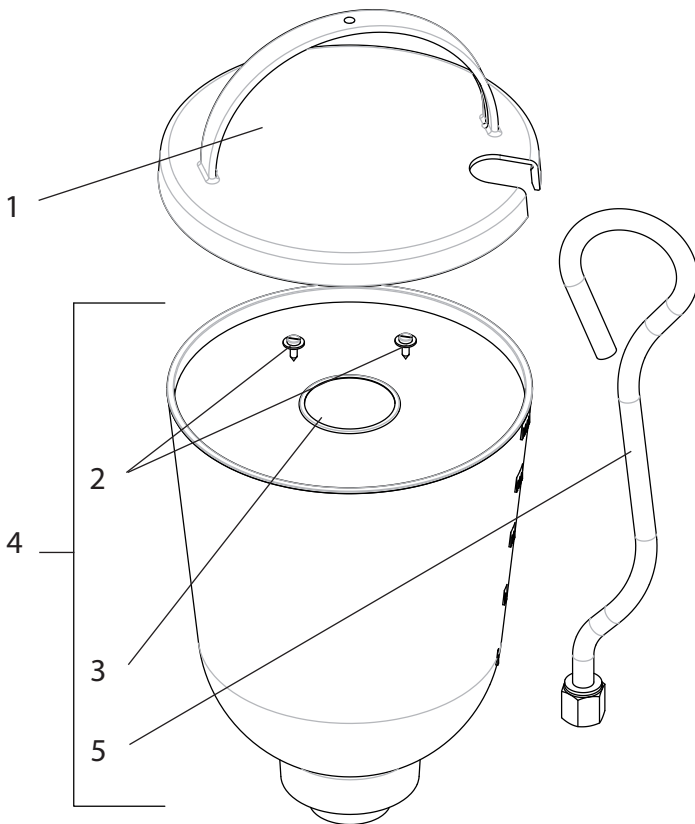

Spare parts diagram hopper

### 11.8 SPARE PARTS LIST HOPPER WITH TOPCLEAN

ITEM	ORDER-NO	DESIGNATION
-	0341 268	Hopper 5l with TopClean, assy.
1	0340 904	Hopper 5l (filter disc see 11.7)
2	0340 901	Cover
3	0340 271	TopClean, assy.
4	0340 270	Return pipe
5	0340 499	Screwing
6	0340 466	Distributor ring
7	0340 500	Rotary valve shaft
8	9971 486	O-ring 4x2 (FFPM)

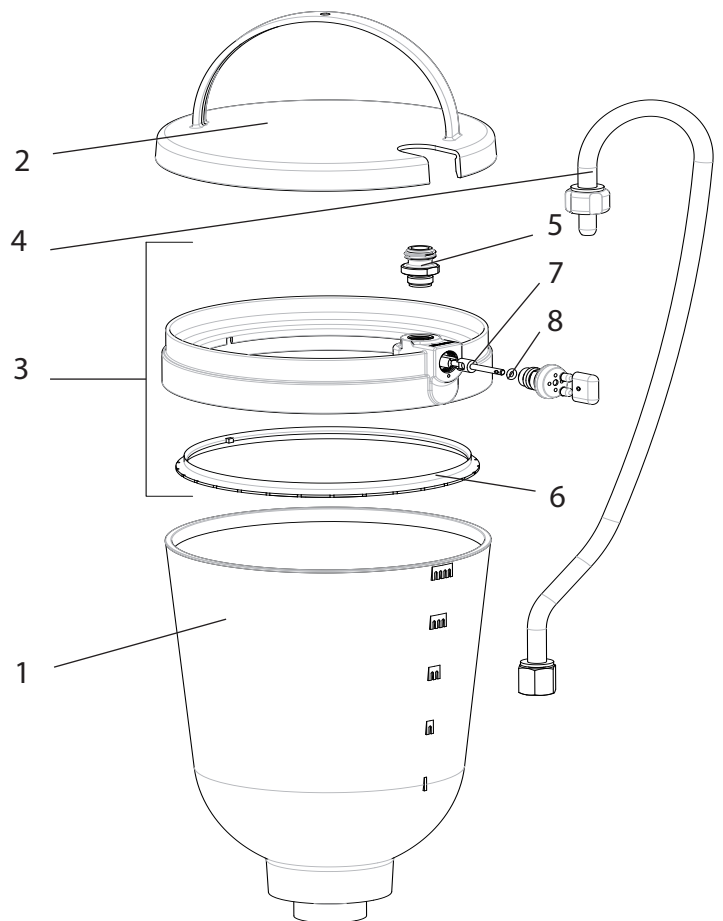

Spare parts diagram hopper with TopClean



J. Wagner GmbH Otto Lilienthal-Str. 18 D-88677 Markdorf



**CE Konformitätserklärung**

**CE Declaration of conformity**

**CE Déclaration de conformité**

**CE Konformiteitsverklaring**

Hiermit erklären wir, daß die Bauart von

Herewith we declare that the supplied version of

Par la présente, nous déclarons, que le type de

hiermede verklaren wij, dat de in de handel gebrachte machine

**WAGNER Finish 250, Finish 270 230V/ 50Hz; Finish 370 100V 50/60Hz**

folgenden einschlägigen Bestimmungen entspricht:

complies with the following provisions applying to it:

correspond aux dispositions pertinentes suivantes:

voldoet aan de eisen van de in het vervolg genoemde bepalingen:

2006/42 EG, 89/336 EG, 73/23 EG

2006/42 EC, 89/336 EC, 73/23 EC

2006/42 CE, 89/336 CE, 73/23 CE

2006/42 EG, 89/336 EG, 73/23 EG

Angewendete harmonisierte Normen, insbesondere:

Applied harmonized standards, in particular:

Normes harmonisées utilisées, notamment:

Gebruikte geharmoniseerde normen, in het bijzondere:

**EN ISO 12100-1/-2 (EN 292-1/-2), EN 1953, EN 60204-1, EN 55014-1/2**

Angewendete nationale technische Spezifikationen, insbesondere:

Applied national technical standards and specifications, in particular:

Normes et specifications techniques nationales qui ont été utilisées, notamment:

Gebruikte nationale technische normen en specificaties, in het bijzondere:

**BGR 500 /2/ Kapitel 2.29, 2.36**

04.05.2007

Datum / Date / Datum

Unterschrift / Signature / Handtekening

Geschäftsführer  
Executive Officer  
Directeur  
Directeur

Entwicklungsleiter  
Head of Development  
Directeur du développement  
Chef ontwikkeling

## TESTING OF THE UNIT

in accordance with the guidelines for liquid jets (spraying units) of the German industrial employer's liability insurance association.

The unit has to be tested when appropriate, however at least every 12 months. by experts whether safe operation continues to be ensured.

In case of non-operative units the test can be postponed until the next start-up.

The operator is obliged to make an appointment for the unit test.

Please contact the WAGNER customer service centers

(This guideline only applies for Germany)

## IMPORTANT INFORMATION ON PRODUCT LIABILITY

An EU directive valid since 01.01.1990 specifies that the manufacturer is only liable for his products if all the parts originate from the manufacturer or are approved by him, and if the units are mounted and operated properly.

If accessories or spare parts from third parties are used, liability can be partially or completely inapplicable. In extreme cases the responsible authorities can prohibit the use of the entire unit (German industrial employer's liability insurance association and factory inspectorate).

With original WAGNER accessories and spare parts, compliance with all safety regulations is guaranteed.

## NOTE ON DISPOSAL

In observance of the European Directive 2002/96/EC on waste electrical and electronic equipment and implementation in accordance with national law, this product is not to be disposed of together with household waste material but must be recycled in an environmentally friendly way!



Wagner or one of our dealers will take back your used Wagner waste electrical or electronic equipment and will dispose of it for you in an environmentally friendly way. Please ask your local Wagner service centre or dealer for details or contact us direct.

## GUARANTEE DECLARATION

**24 months, at two-shift operation 12 months, at three-shift operation 6 months**

We give a works guarantee to the following extent for this unit:

All those parts that prove to be unserviceable or to be considerably impaired in their serviceability within 24 months in

case of single-shift operation, 12 months in case of two-shift operation or 6 months in case three-shift operation since the point of handing over to the buyer due to a circumstance lying before this handing over – in particular due to faulty design, bad building materials or poor execution – are improved or supplied new as we choose without costs.

The guarantee is given in the form that the unit or individual parts of it are replaced as we decide. The costs required to this purpose, in particular transportation, road, working or material costs, are borne by us unless the costs increase because the unit has been brought subsequently to a place that is not the location of the customer.

We do not accept any guarantee for damage that has been caused by the following reasons:

Unsuitable or incorrect usage, faulty mounting or starting-up by the buyer or by third parties, natural wear, faulty handling or maintenance, unsuitable coating materials, substitute materials and chemical, electrochemical or electrical influences, in as far as damage is not due to our fault. Abrasive coating materials, such as minium, dispersions, glazes, liquid abrasive materials, etc. reduce the durability of valves, packings, spray guns, tips, cylinders, pistons, etc. Any resulting signs of wear are not covered by this guarantee.

Components that were not manufactured by Wagner are subject to the original manufacturer warranty.

The replacement of a part does not extend the guarantee period of the unit.

The unit has to be examined immediately after receipt. Obvious faults are to be reported in writing within 14 days after receipt of the unit in order to avoid loss of the rights arising from faults.

We reserve the right to have the guarantee fulfilled by a contractual company.

Fulfilling of the guarantee depends on proof being provided by invoice and delivery note. If the check shows that the case is not a guarantee case, repairs are carried out at the expense of the buyer.

We make it clear that the guarantee declaration does not represent a limitation of the statutory rights or of the rights agreed contractually through our general terms of business.

**J. Wagner GmbH**

Subject to modifications · Printed in Germany

**SERVICENETZ / SERVICE NETWORK / RÉSEAU DE SERVICE APRÈS-VENTE**
**RETE DI ASSISTENZA /SERVICENETWERK**

<b>AUS</b>	Wagner SprayTech Australia PTY LTD. POB 286 14-16 Kevlar Close Braeside, VIC. 3195 Phone: +61/ 03/ 9587 2000 Fax: +61/ 03/ 9580 9120 wagner@wagnerspraytech.com.au	<b>DK</b>	Wagner Spraytech Scandinavia A/S Helgeshøj Allé 28 2630 Taastrup Denmark Tel. +45/43/ 27 18 18 Telefax +45/43/ 43 05 28 wagner@wagner-group.dk	<b>I</b>	Wagner Colora Via Fermi, 3 20040 Burago di Molgora (MI) Italia Tel. +39/ 039 / 625 021 Telefax +39/ 039 / 685 18 00 info@wagnercolora.com
<b>A</b>	J. Wagner Ges.m.b.H. Ottogasse 2/20 2333 Leopoldsdorf Österreich Tel. +43/ 2235 / 44 158 Telefax +43/ 2235 / 44 163 Gerhard.Poisinger@wagner-group.at	<b>E</b>	Wagner Spraytech Iberica S.A. Apartado 132 08750 Molins de Rey Barcelona / Espania Tel. +34/93/6800028 Telefax +34/93/66800555 info@wagnerspain.com	<b>NL</b>	Wagner Spraytech Benelux b.v. Zonneban 10, 3542 EC Utrecht Netherlands Tel. +31/ 30/241 41 55 Telefax +31/ 30/241 17 87 info@wagner-wsb.nl
<b>B</b>	Wagner Spraytech Benelux b.v. Veilinglaan 56 1861 Wolvertem-Meise Belgium Tel. +32/2/269 46 75 Telefax +32/2/269 78 45 info@wagner-wsb.be	<b>F</b>	J. Wagner France S.A.R.L 5 avenue du 1er mai, B.P. 47 91122 Palaiseau-Cedex France Tel. +33/1/825 011 111 Telefax +33/1/698 172 57 division.batiment@wagner- france.fr	<b>NZ</b>	SprayTech New Zealand Ltd. P.OB 10353 unit 6/671 Te Rapa Road Hamilton Phone: +64/ 07/ 849 1329 Fax: +64/ 07/ 849 3185 sales@spraytech.co.nz
<b>CH</b>	Wagner International AG Industriestrasse 22 9450 Altstätten Schweiz Tel. +41/71 / 7 57 22 11 Telefax +41/71 / 7 57 22 22 wagner@wagner-group.ch	<b>CZ</b>	Wagner, spol.s r.o. Nedasovská str. 345 155 21 Praha 5 -Zlicín Czechia Tel. +42/ 2 / 579 50 412 Telefax +42/ 2 / 579 51 052 info@wagner.cz	<b>S</b>	Wagner Spraytech Scandinavia A/S Helgeshøj Allé 28 2630 Taastrup Denmark Tel. +45/43/ 21 18 18 Telefax +45/43/ 43 05 28 wagner@wagner-group.dk
<b>D</b>	J. Wagner GmbH Otto-Lilienthal-Straße 18 D-88677 Markdorf Postfach 11 20 D-88669 Markdorf Deutschland Tel.: +49 / 75 44 / 505 - 540 Fax: +49 / 75 44 / 505 -169 wagner@wagner-group.com www.wagner-group.com	<b>GB</b>	Wagner Spraytech (UK) Ltd. Unit 3 Haslemere Way Tramway Industrial Estate Banbury, Oxfordshire OX 16 5RN Great Britain Tel. +44/ 12 95 / 265 353 Telefax +44/ 12 95 / 269 861 enquiry@wagnerspraytech.co.uk		